

IMPROVING CAMPUS CHILLED WATER SYSTEMS WITH INTELLIGENT CONTROL VALVES: A FIELD STUDY

Gregor P. Henze

*Department of Civil, Environmental and Architectural Engineering
University of Colorado Boulder
Boulder, Colorado
Email: gregor.henze@colorado.edu*

Walter Henry

*Massachusetts Institute of Technology
Cambridge, MA
Email: whenry@plant.mit.edu*

Marc Thuillard

*Belimo Automation AG
Hinwil, Switzerland
Email: marc.thuillard@belimo.ch*

ABSTRACT

The degradation of the temperature difference between supply and return flow, known as ΔT degradation, in chilled water systems has been widely observed and documented over the last 25 years. High pumping energy consumption as well as reduced efficiency of the chillers operating under part-load conditions, lead to a decrease of overall system efficiency of chilled water plants. This article describes a field study conducted on two university campuses in Massachusetts and Colorado during the cooling season of 2011. The purpose of this experimental study was to alleviate ΔT degradation problems on both campuses through the use of intelligent pressure-independent control valves, and to quantify the improvements achieved. The MA field results revealed that the intelligent control valves when coupled with a ΔT management strategy have allowed the campus to serve additional cooling load on its campus with the same distribution and central plant system.

Keywords: chilled water plants; delta T degradation; energy efficiency; building retrofits;

INTRODUCTION

The degradation of the temperature difference between supply and return flow, known as ΔT degradation, in *chilled water systems* has been widely observed and documented over the last 25 years. While commonly the problem of decreasing waterside temperature difference is reported, the real problem is the corresponding increase in water flow rate. Especially under part-load conditions, when the mass flow rate relative to the cooling load increases, an additional chiller and cooling tower need to be brought online to maintain the flow requirements even though the cooling capacity limits of the chillers have not yet been reached. Both, high pumping energy consumption as well as reduced efficiency of the chillers operating under part-load conditions, lead to a decrease of overall system efficiency of chilled water plants.

Common causes of low ΔT in chilled water plants include oversized control valves (leading to two-position behavior, valve hunting, and suboptimal use of flow), lack of hydraulic balancing, and fouled cooling coils (Taylor 2002). For illustration purposes, imagine a central chilled water plant equipped with two 200-ton chillers in parallel, each served by a dedicated chilled water pump controlled by a variable frequency drive. Assuming that the plant operates as designed at a 12°F (6.7K) ΔT between chilled water supply and return temperature, a load of 180 tons (633 kW), constituting a 45% plant part load, would lead to a 360 GPM (22.7 L/s) distribution loop flow and call for only one of the two chillers operating at 90% of its capacity, as shown in Figure 1 on the left. If, however, for reasons named above, the ΔT has degraded from 12°F to 10.4°F (5.8K), serving the same load of 180 tons (633 kW), would now require 414 GPM (26.1 L/s) of distribution loop flow, i.e., 15% more than in the case of as-designed operation, in response starting the second chiller and potentially another cooling tower based on flow demand, yet not in response to cooling demand since the load is still 180 tons. Each of the two chillers operate at a much lower part-load ratio of 45% with a loss in central plant efficiency associated with operating two chillers at low part-load rather than one chiller near capacity.

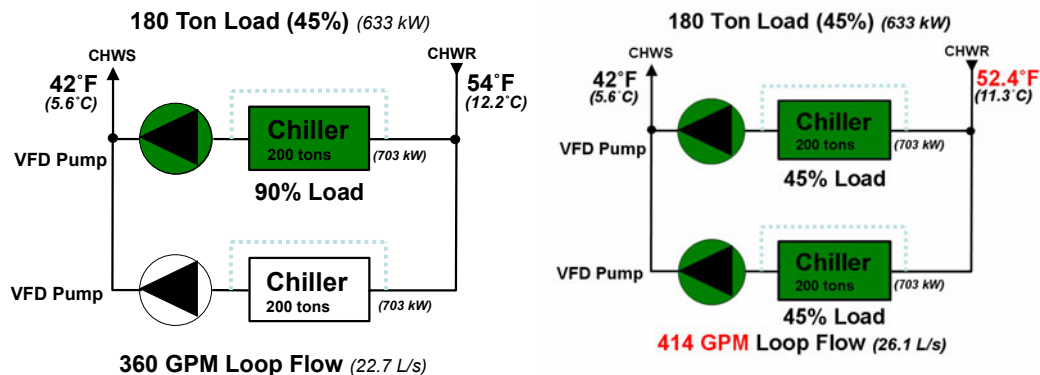

Figure 1: Central chilled water plant operating at design of 12°F (6.7K) (left) and degraded of 10.4°F (5.8K) (right)

Moreover, due to changes of technology in *central heating plants* such as condensing boilers and combined heat and power systems over the past 15 years, the problem of ΔT degradation has also been observed in many heating applications. Especially in large heating systems such as those used for district heating, the return water temperature has a significant influence on the overall system efficiency.

This article describes a field study conducted on the campuses of the Massachusetts Institute of Technology (MIT) and the University of Colorado Boulder (UCB) during the cooling season of 2011. The purpose of this experimental study was to alleviate ΔT degradation problems on both campuses through the use of advanced pressure-independent control valves, and to quantify the improvements achieved. The flow control devices deployed, five at MIT and six at UCB, are novel two-way exponential (equal-percentage) control valves mated with a magnetic flow meter, temperature sensors in both waterside supply and return lines, and several microprocessors, that can carry out a multitude of control strategies. The intelligent control valve has internet capabilities and different strategies can be downloaded remotely using internet and the built-in web server.

These novel control valves are independent of pressure fluctuations in the distribution loop as the flow through each coil is controlled directly by the control signal, rather than indirectly through a valve position. Should the upstream pressure change at a particular flow request, the microprocessor will adjust the valve position through a device-internal cascaded control loop. Conversely, a conventional pressure-dependent control valve would suffer a flow variation, which would first need to be detected by the coil control loop and then corrected thereafter. Moreover, by measuring flow and ΔT at the same time, waterside cooling loads can be calculated and a coil characteristic of load versus water flow be established over time, which may serve diagnostic purposes.

A novel feature of the installed valves, derived partially from Hartman (2000), is a strategy that combats low ΔT , which is explained in greater detail in Figure 3 below: The primary ΔT logic loop is constantly monitoring the measured ΔT and compares it to the ΔT_{lim} setpoint. If ΔT is lower than its setpoint plus a hysteresis value, the ΔT logic calculates a new flow setpoint to maintain the desired ΔT_{lim} setpoint.

LITERATURE REVIEW

Though increasingly variable primary systems are adopted, in many older facilities the design of large chilled water systems has been dominated by decoupling the primary chilled water plant flow from the secondary load side water flow by means of a bypass line. In addition, the load side distribution networks are frequently equipped with bypass lines on individual loads to avoid operating constant speed pumps against closed control valves. According to chiller manufacturers, in cooling systems, the primary/secondary design requiring constant flow in the primary loop was due to chiller control stability issues. Conversely, in central heating systems, the approach originates back to a high return temperature being required in order to avoid condensation in the boilers with associated corrosion damage. The load side bypass lines as well as the primary/secondary configuration in conjunction with constant speed pumps, lead to constant primary and secondary mass flow rates and to ΔT degradation under part-load conditions in both chilled water plants and central heating applications.

Particularly in older primary/secondary chilled water system configurations, the high distribution side mass flow rate, as a result of constant speed pumping, leads to high pumping energy consumption. Peyer and Bahnfleth (2006) showed that the additional amount of pump energy due to the excess primary flow associated with primary/secondary systems, while not huge, is significant. A secondary problem is the resultant difficulty in controlling the chillers, as additional chillers need to be brought online to maintain adequate flow requirements even though the cooling capacity limits of the chillers have not yet been reached. Both effects result in overall reduced system efficiency. For that reason, numerous investigators such as Reed (2007), Harrell (2009), Taylor (2006), and Ma (2010) propose several possibilities including bypass check valves, variable speed pumps, and variable flow primary loop to reduce bypass mass flow and increase efficiency. Taylor (2002) and Fiorino (1996) provide a comprehensive overview of the various possibili-

ties to reduce the mass flow rates in hydraulic systems under typical operating conditions with the intention to increase the temperature difference between supply and return flow. Both authors mention that oscillation of control valves around their respective setpoints (e.g., due to oversized control valves) leads to a higher average mass flow rate than desired, and thus ΔT is degraded; however, the extent of ΔT degradation is not quantified.

In a study of a different campus, the University of California Riverside was experiencing many problems with their chilled water system, which resulted in a low waterside temperature differences and even negative differential pressure measurements at remote loads. Hyman and Little (2004) report that a 1°F (0.6K) drop in delta-T results in a 5% loss in capacity of the chilled water thermal energy storage system. As the campus grew, the existing thermal energy storage system could no longer offset the cooling demand.

Similarly, in large central heating systems, ΔT degradation plays an ever-increasing role. Floss (2006) points out that condensing boilers require a very low return water temperature to the boiler to achieve a significant condensing effect and the expected high efficiency. In practice, many combined heat and power plants go offline or initiate the emergency cooling when the return flow temperature exceeds 160°F (71°C). The causes for high return water temperatures in central heating systems are the same as low return water temperatures in chilled water systems: The mass flow is not adjusted downward as the loads drop, leading to excessive water flow rates and ΔT degradation.

For district heating systems, ΔT degradation has three efficiency detriments, which are higher pumping energy consumption, higher heat losses in the warm return pipes, and lower primary energy efficiency in heat and power generation. Moreover, the high mass flow rates at low ΔT limit the maximum heating capacity that can be provided by the district heating system, preventing the opportunity to grow the reach of the district heating network to new customers.

COOLING COIL PERFORMANCE MODELING

A simulation tool was developed to generate performance maps based on established relationships for dry and wet cooling coils presented by McQuiston, Parker and Spitler (2005) in order to establish expected coil behavior for a range of operating conditions, before analyzing any operational data. Consider a cooling coil served with a variable chilled water flow of up to 6.3 L/s (100 GPM) at temperatures of either 5°C (design) or 9°C (far too warm). The entering mixed airflow of a constant 3,540 L/s (7,500 CFM) is at 28°C and either 40% (moderate) or 80% (high) relative humidity. Defining the normalized total (sensible and latent) coil load q_{Tot} as the current load met at a particular chilled water flow to the total load achieved at maximum flow of 6.3 L/s and the normalized flow ϕ as the current flow to the maximum flow, one can develop characteristic coil maps for each of the entering water and air states as shown in the upper graph of Figure 2. In addition, in the lower graph one can see the development of the waterside ΔT [K]. The green lines refer to the more humid entering air state and the dashed lines depict the warmer entering water temperature. While the maximum total load for the cold supply water of 5°C and

humid entering air of 28°C and 80% RH, at 161 kW is much higher than the 71 kW for warm chilled water and dryer entering air, nonetheless, the *normalized coil characteristic* remains nearly unchanged. At 40% normalized flow, 90% of the maximum total coil load is delivered. To deliver the next 6% of capacity, the flow must be doubled from $\phi = 0.4$ to 0.8 , an effect of diminishing returns referred to as *saturation*. The intelligent control valve presented here is parameterized to reveal flow saturation that occurs for high values of normalized flow such as $\phi > 0.6$, i.e. here > 60 GPM by harnessing a model of the cooling coil being controlled that was calibrated during valve commissioning.

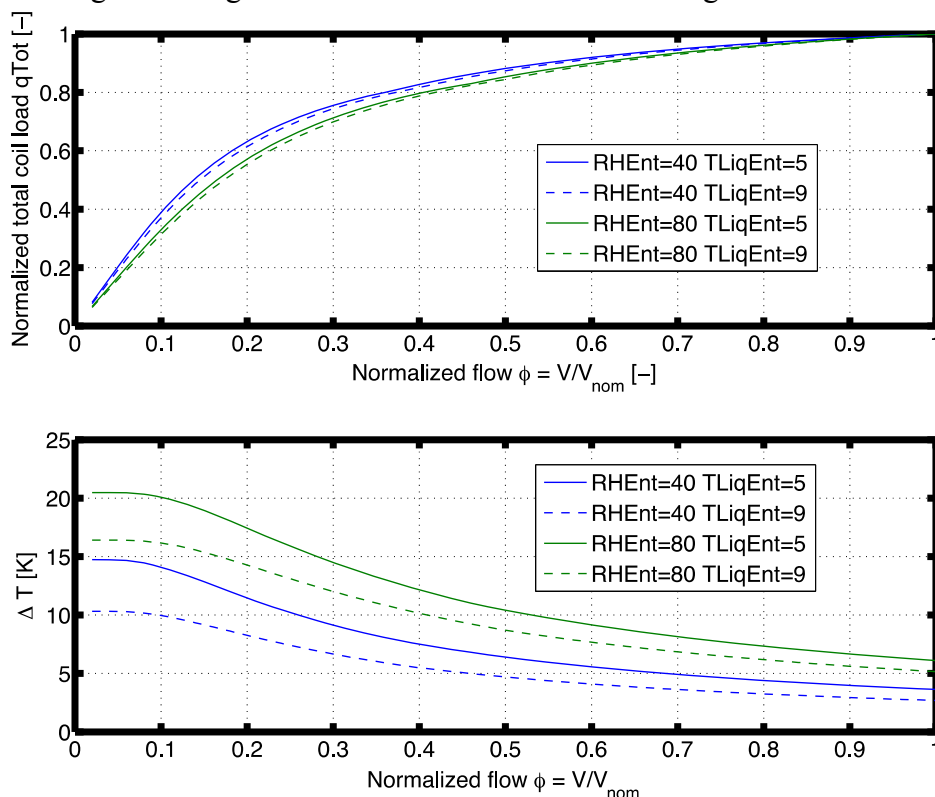

Figure 2: Coil Performance Map (top) and ΔT Development with Norm. Flow (bottom)

The careful reader will notice that limiting ΔT must be carefully deployed. Choosing for instance a low ΔT_{lim} of 6 K, limits the normalized flow to 55% and the coil total load to $q_{Tot}=91\%$ when the entering chilled water is at its design of 5°C and the entering air is at 40% RH. Under very humid entering air conditions, the same ΔT_{lim} leads to a much higher normalized flow of 95% and $q_{Tot}=99\%$. In other words, a $\Delta T_{lim}=6K$ allows the coil to deliver $> 90\%$ of its maximum capacity. Conversely, choosing a high ΔT_{lim} of 12 K, limits the normalized flow to 20% and the coil total load to $q_{Tot}=65\%$ when the entering chilled water is at its design of 5°C and the entering air is at 40% RH. Under very humid entering air conditions, the same ΔT_{lim} leads to a much higher normalized flow of 42% and $q_{Tot}=80\%$. An engineering software tool was developed that analyzes coil operational data for several weeks to ensure that the ΔT_{lim} chosen is not too high so that the heat exchanger is always allowed to approach the saturation region, i.e. without excessively curtailing coil load delivered. For the Massachusetts campus field study, a ΔT_{lim} of 6.7 K (12°F) was chosen using said tool.

DESCRIPTION OF CAMPUS CHILLED WATER SYSTEMS

In Massachusetts, the university campus central chilled water system consists of 30,400 tons (107 MW) of absorption and electric centrifugal chillers. An internal study conducted in 2008 showed a plant ΔT as low as 2°F (1.1K) with an average annual ΔT of approximately 6°F (3.3K). The study also estimated that annual savings of \$1.5M would accrue if the average ΔT could be improved to 12°F (6.7K). One building with very low ΔT is the Hayden Library: This 1947 vintage building was built with its own chiller and later converted to campus district cooling. The air handler coils were designed in 1947 for a 6°F (3.3K) ΔT assuming 50°F (10°C) entering and 56°F (13.3°C) leaving temperature. However, today the plant is operating at 44°F (6.7°C) entering water temperature, offering the potential for much higher coil capacities and waterside ΔT , yet the building was operating at a ΔT of only 2 to 6°F (1.1 to 3.3K). A detailed description of the pilot projects undertaken in the building to increase ΔT is provided below.

DESCRIPTION OF RETROFIT PROJECT

The main library on the Massachusetts campus is a three-story 153,000 gross square foot (14,286 m²) building constructed in 1947. In addition to a number of fan coils, the building is conditioned by six air handlers ranging in capacity from 7,500 to 30,000 cfm (3,540 to 14,160 L/s).

As mentioned above, the coil ΔT on most air handlers averaged 6°F (3.3K). The principal cause of the low ΔT was over-pumping of the coils. To improve this situation, two control strategies were tested in a pilot project. Initially, two air handlers were tested, one using a ΔT control strategy applied to a new motorized conventional, i.e. pressure dependent, globe valve that replaced a deteriorated existing one and the other using a pair of pressure independent ΔT control valves. Two tandem valves were used because the required flow rate for the coil exceeded the capacity of the (then available) pressure independent valves of that type. These valves were at that time not equipped with the flow meters that are part of the intelligent control valves today, but rather used a mechanical pressure independent mechanism. A new globe valve was installed so that a comparison between pressure independent and pressure dependent valves could be conducted. All three valves on the two air handlers used the same ΔT control strategy: Both approaches increased the ΔT of the air handlers to 12°F (6.7K) but the pressure independent arrangement gave better control as indicated by a smaller standard deviation of only 0.7°F (0.4K) as compared to a standard deviation of 1.5°F (0.8K) for the pressure dependent valve. The conclusion is that both the pressure independence *and* the ΔT management strategy were required to get the best and most consistent result.

As larger pressure independent valves with the ΔT strategy had become available in the meantime, the remaining four air handlers, along with the one that had used the new globe valve, were now retrofitted and tested with new intelligent control valves. Air handling unit AHU-5, equipped with the mechanically pressure independent valves and ΔT manager, was left in that configuration as the setup was performing well. Since this valve

arrangement lacks the accurate flow measurement of the intelligent control valves (magnetic flow meter), it is excluded from the detailed data analysis.

A prototypical retrofit scenario is sketched in Figure 3, which shows the cooling coil in an air-handling unit, equipped with intelligent control valve that receives the analogue input signal from the building automation system just as any other control valve would. For the purpose of acquiring evidence on the performance of these valves in this experimental study only, each valve was connected to a dedicated laptop, data acquisition software, and a wireless Internet connection for remote monitoring and maintenance.

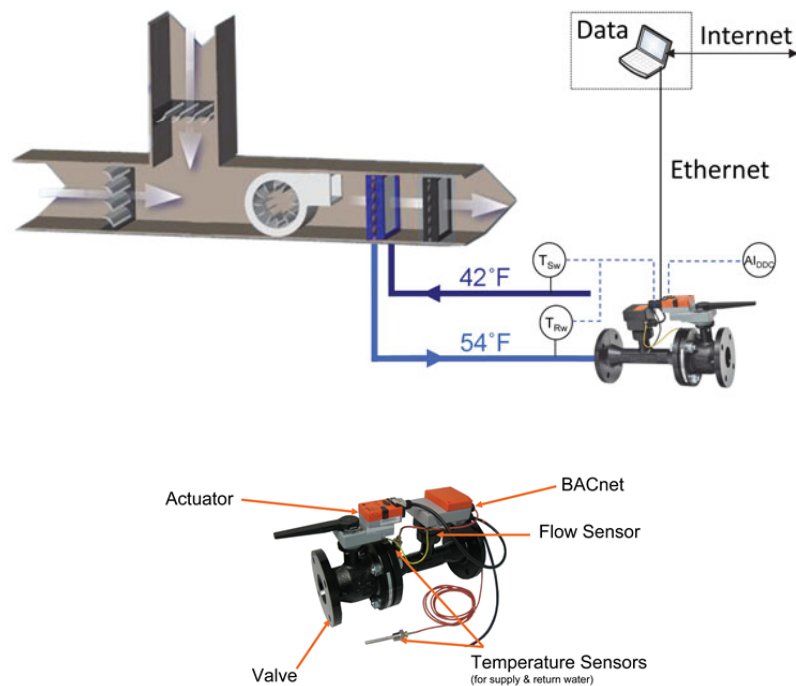

Figure 3: Case Study Experimental Setup (top) and Intelligent Control Valve (bottom)

RESULTS

Figure 4 documents the findings for one of the Massachusetts library cooling coils, AHU-6, shown as a cooling power [Btu/h] vs. water flow rate [GPM] with the data being collected by the control valve itself, and not a separate data acquisition system. As flow increases from 0 to 60 GPM (0 to 3.8 L/s), cooling power increases from 0 to 300 kBtu/h (0 to 88 kW), yet a clearly exponentially decaying behavior can be observed: While the first 20 GPM (1.3 L/s) provide roughly 180 kBtu/h (53 kW), the last 20 GPM from 40 to 60 GPM (2.6 to 3.8 L/s) provide an incremental increase of less than 40 kBtu/h (12 kW). The waterside temperature difference, starting with roughly 25°F (14K) drops with increasing flow rate to 5°F (2.8K), in an approximately inverse trend to the cooling power. Both thermal power output and waterside temperature difference show the behaviour expected from the coil analysis shown in Figure 2.

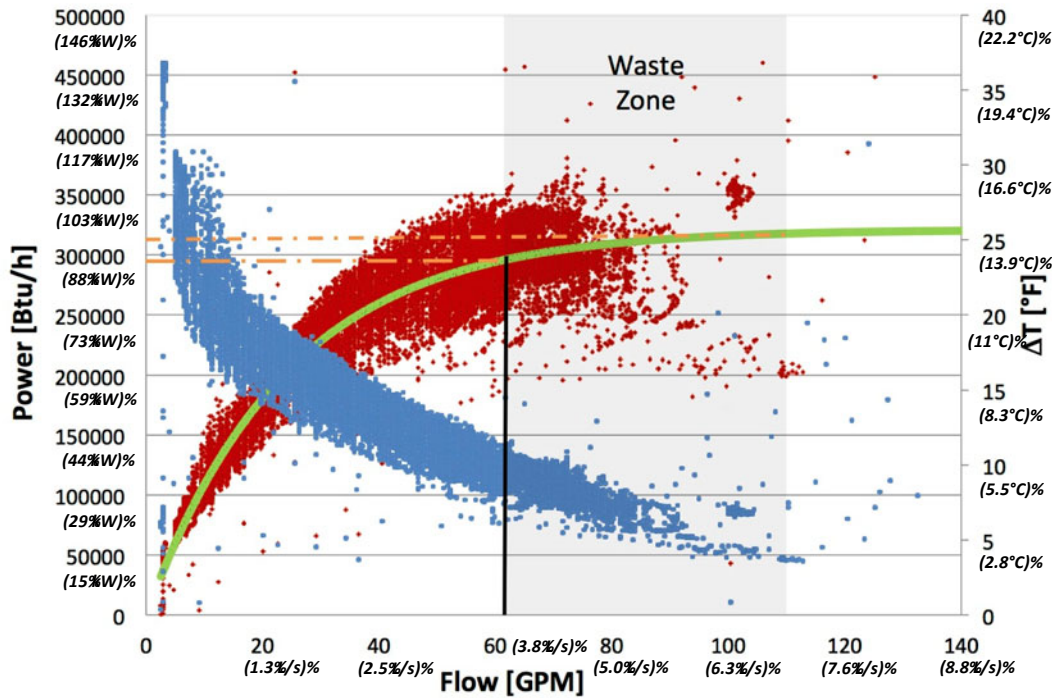

Figure 4: AHU-6 Cooling Coil Performance July 1-22, 2011 (power in red and in blue)

The intelligent control valve’s ability to monitor the total cooling delivered vs. flow rate, allows for a characterization of the coil response. Continuous monitoring would recognize changes in the coil characteristic over time to enable fault detection such as coil fouling. In addition, the coil performance characterization now possible is useful under operating conditions that are substantially different from the design conditions as in the case of the Hayden Library coils: The improvements reported here were achieved (in five of the six cases) with the original coils that were designed in 1947 for only a 6°F (3.3K) ΔT, i.e. rather short cooling coils. The fact that coils with such low design temperature differences can actually deliver higher levels of cooling is deemed important as it contradicts the assumption that a coil exchange is a prerequisite to improving plant ΔT performance.

As anticipated from the analysis, an effect of diminishing returns of coil output with increasing water flow is evident in Figure 4. If an operator would know the marginal benefit of pumping the last 20 GPM (1.3 L/s) through AHU-6 as well as the associated drop in temperature difference from 14 to 10°F (7.8 to 5.6K), he/she may decide to withhold the additional flow and the associated pump power, along with a marginal loss of coil capacity. However, detecting this saturation effect is not trivial as it depends on the entering air state and flow and, in particular, on the entering water temperature. In fact, in the five cooling coils retrofitted on the MA university campus, the extent of the ΔT degradation was very different. In the field study, it was decided to implement a ΔT manager strategy that limits chilled water flow such as that ΔT does not fall below 12°F (6.7K). Figure 4 reveals that this ΔT_{lim} setting indeed allows for saturation to occur, i.e. for the coil to deliver almost all of its capacity.

It should be pointed out that by monitoring the power vs. flow curve, the waste zone could be defined by either a ΔT limit or a flow limit, both values being closely related to each other. The ΔT manager implements either a ΔT limit or a flow limit for operation. Depending on the application, one setting may be preferred over the other. In the case of the MA campus case study, both strategies offered similarly good results.

In tallying the number of hours of saturation during the 2011 cooling period, it became obvious that the five (intelligent control valve equipped) air-handling units suffered from saturation and the associated ΔT degradation to very different extents, as shown in Figure 5. While AHU-4 (retrofitted with a deeper cooling coil and 14°F [7.8K] design ΔT) and AHU-1 reveal on the order of 10-15% of saturated hours, coils AHU-2, 3, and 6 are saturated between 40% and 80% of the time. Even an experienced building operator would be hard pressed to identify a priori, which of the coils in a distribution loop is most likely suffering from power saturation most and thus a device-level intelligence is preferred in identifying this condition.

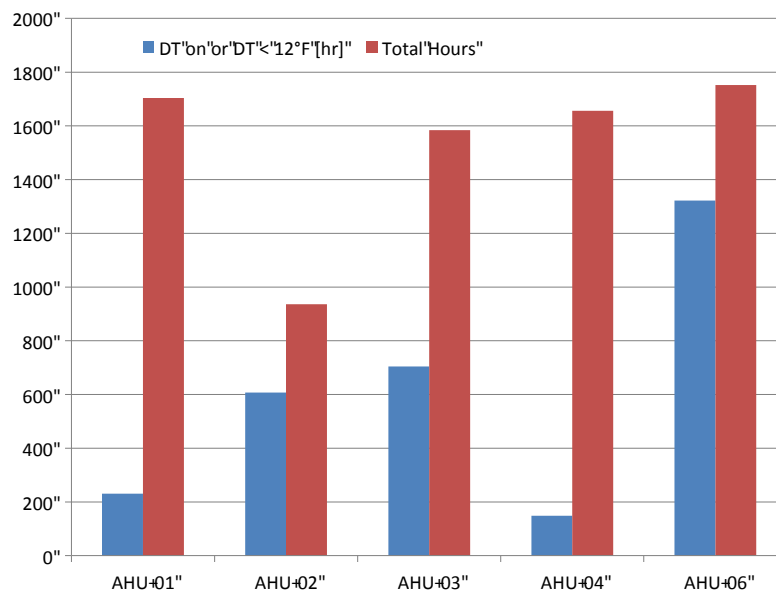

Figure 5: MA Campus Library Total and Saturated Operating Hours During 2011

An experiment similar to the one on the MA campus was repeated in Colorado. The CO campus central plant has had issues with a low ΔT syndrome from several campus buildings, which resulted in over-pumping of the central plant system and plant-wide ΔT as low as 4°F (2.2K). Its music building is one of the closest buildings to the central plant, demanding a lot of water flow with not a significant ΔT returning to the central plant and was chosen to determine whether providing pressure independent valves would free up capacity for buildings that were more hydraulically remote. Data collection in CO continues through 2012, but trends similar to Figure 6 have been confirmed. In addition, the CO campus has several buildings that need to be added to the central plant chilled water system. The pressure independence would free up more capacity as well with the hope that it could save on capital investment of increasing plant and pipe size to accommodate future growth on the campus without having to provide new or replace existing piping.

SUMMARY

In assessing the impact of the retrofit of the six AHU (five with intelligent control valves and one with a mechanical pressure independent valve) in a library on a Massachusetts campus, it is illustrative to compare the average building-wide chilled water temperature on the district cooling system for two identical time frames of 2010 and 2011. From Aug 9 to Oct 9, 2010, i.e., before the retrofit, the building-wide average ΔT was measured to be merely 6.15°F (3.42K). After retrofitting the six cooling coils, the average ΔT of the library has essentially doubled to 12.14°F (6.74K) as confirmed by post-retrofit measurements. It is thus evident that the pressure independent valves when coupled with a ΔT management strategy have vastly improved the load-to-flow relationship of this building. This improvement allows the campus to serve additional cooling load on its campus with the same distribution and central plant system as the central cooling plant is no longer choked to deliver cooling by excessive flow requirements in the distribution loop.

REFERENCES

- Bahnfleth, W. and E. Peyer (2006) "Energy use and economic comparison of chilled water pumping alternatives." *ASHRAE Transactions* Vol. 112 Pt.2, pp.198-208.
- Fiorino, D.P. (1996) "Twenty-five ways to raise your chilled-water temperature differential." *ASHRAE Transactions*, Vol. 102 Pt. 1, pp. 567-572.
- Floss, A.G. (2005) "Effizienzmessung bei Brennwert-Heizungsanlagen." IHKS Fachjournal 2005/2006 (Fachzeitschrift für Planungsbüros, Anlagenbau, Öffentliche Hand und Fachhandel), pp. 94-97.
- Hartman, T.B. (2000) "High-efficiency pumping and distribution system incorporating a self-balancing, modulating control valve." U.S. Patent No. 6,352,106, U.S. PTO.
- Harrell, J.M. and Mathias, J.A. (2009) "Improving efficiency in a campus chilled water system using exergy analysis." *ASHRAE Transactions*, Vol. 115 Pt. 1, pp. 507-522.
- Hyman, L.B. and D. Little. "Overcoming Low Delta-T, Negative Delta-P at Large University Campus." *ASHRAE Journal*, February 2004: 28-34.
- Ma, Z. and Wang, S. (2010) "Enhancing the performance of large primary-secondary chilled water systems by using bypass check valve." *Energy* doi:10.1016/j.energy.2010.10.042
- McQuiston, F., J. Parker, and J. Spitler (2005) *Heating, Ventilating, and Air Conditioning*. Sixth Edition. John Wiley & Sons, Inc.
- Reed, M.A. and Davis, C. (2007) "Chilled water plant savings at no cost." *Energy Engineering*, Vol. 105 Pt. 2, pp. 59-76.
- Taylor, S.T. (2006) "Chilled water plant retrofit – a case study (Sonoma State University)." *ASHRAE Transactions*, Vol. 112 Pt. 2, pp. 187-197.
- Taylor, S.T. (2002) "Degrading Chilled Water Plant Delta-T: Causes and Mitigation." *ASHRAE Transactions*, Vol. 108 Pt. 1, pp. 641-653.