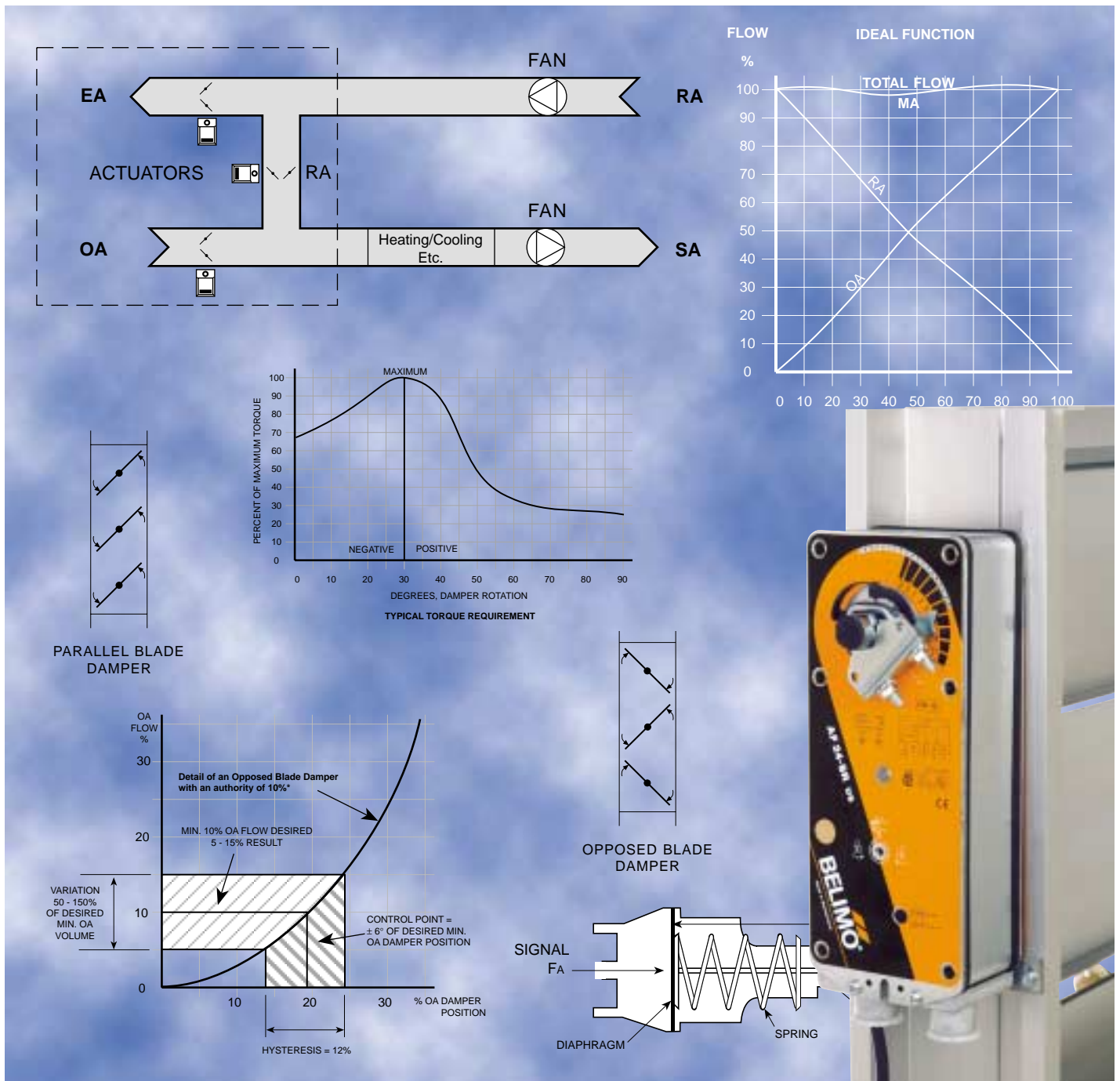


## Damper Applications Guide

### Constant Volume Damper and Actuator Characteristics

# 5.3



## INDEX

<b>I. INTRODUCTION</b>	
A. Economizer Systems .....	3
B. Indoor Air Quality .....	3
C. Damper Selection .....	3
<b>II. DAMPER SELECTION</b>	
A. Opposed and Parallel Blade Dampers .....	3
B. Flow Characteristics .....	4
C. Damper Authority .....	4
D. Combined Flow .....	6
<b>III. ADDITIONAL CONSIDERATIONS</b>	
A. Economizer Systems .....	6
B. Building Pressure .....	8
C. Mixed Air Temperature Control .....	8
D. Actuators - General .....	8
E. Hysteresis .....	9
F. Accuracy .....	9
G. Actuators - Pneumatic .....	10
H. Positioners .....	11
I. Torque .....	11
J. Linkage .....	11
K. Actuators - Electronic .....	12
L. Electronic Actuators - Conventional Crank Arm Type .....	12
M. Electronic Actuators - Direct Coupled .....	13
<b>IV. OPTIMIZING ECONOMIZER SYSTEMS</b>	
A. Sizing of Dampers .....	14
B. Linearization .....	15
C. Range Controller .....	15
D. Choice of Dampers .....	16
<b>V. ADVANTAGES</b>	
A. Direct Coupled Actuators .....	17
B. Range Controller .....	17
<b>VI. MODERNIZATION OF OLD INSTALLATIONS</b>	
.....	17
<b>VII. SUMMARY</b>	
.....	17

## REFERENCES

Air Movement and Control Association, Inc. (AMCA) Publication 502-89

American Society of Heating, Refrigerating and Air-Conditioning Engineers, Inc. (ASHRAE)  
1991 Applications Handbook, sec. 41.6

We would like to thank Bengt Carlson, Energy Management Consultant, the primary contributor to this book, along with Larry Felker, Area Sales Manager, and Robert Balkun, Product Manager, for their efforts in creating this Application Guide.

If you have any comments on the information given or possible additions, please send them to Robert Balkun, Product Manager, Belimo Aircontrols (USA), Inc., P.O. Box 2928, Danbury, CT 06813, (800) 543-9038, in CT (203) 791-9915, FAX (203) 791-9919.

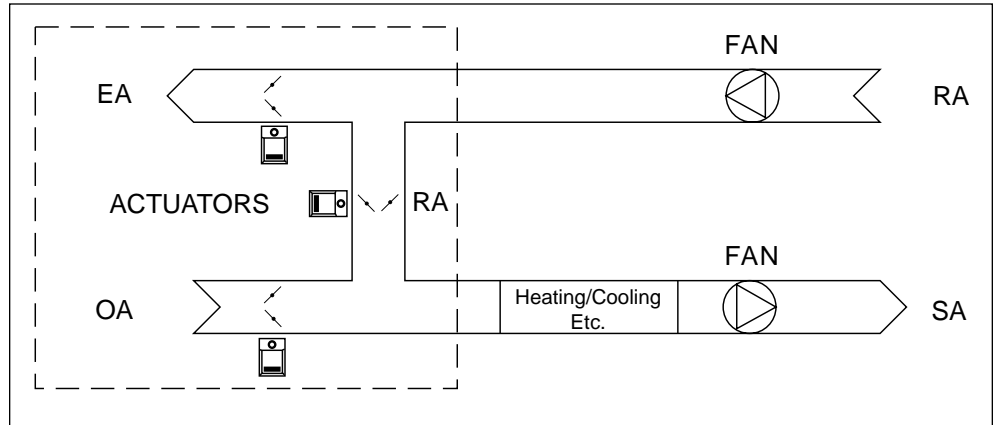
The ideas and concepts shown in this book are based on standard, HVAC engineering guide lines. The use of the information given must be used with sound engineering judgement. Belimo Aircontrols does not take responsibility for problems caused by the concepts given in this publication.

All the contents of this publication are the sole property of Belimo Aircontrols (USA), Inc. and may not be reproduced without the written authorization of Belimo Aircontrols (USA), Inc. © 1999 Belimo Aircontrols (USA), Inc.

**I. INTRODUCTION**

**I-A. Economizer Systems**

The economizer portion of an air-handling system is not only responsible for reducing the operating cost of the system, but more importantly, it has to provide a sufficient volume of outside air at all times to ensure good indoor air quality. The function of the economizer also affects the pressurization of the building. A slight positive pressure is needed to prevent infiltration of unconditioned outside air. Otherwise the indoor climate can be adversely affected due to draft and cold perimeter walls.



**Fig. 1 - Economizer System**

This is typically compensated for by increasing the room temperature, which increases the operating cost. However, too high pressure causes exfiltration, which increases the heat losses. Also, an incorrect pressurization may cause damages to the building structure due to condensation, freezing etc. See Fig. 1.

**I-B. Indoor Air Quality**

The indoor air quality and comfort is much more important than the operating cost of the air handling system. If it is not adequate, absenteeism and turnover will increase and productivity will suffer. This is a hidden cost, which is hard to quantify, but nevertheless, it is a very large cost that can seriously affect the bottom line of any organization. Just imagine what the cost of a few percent decrease in the productivity can be. While the cost of air conditioning typically is \$2/sq. ft., the cost of productive workers is \$150/sq. ft.

The ventilation system is the cause of almost half the indoor air quality complaints according to NIOSH (National Institute of Occupational Safety and Health). Damper control alone is itself not responsible for the indoor air quality and climate, but it has a very central role. Therefore, it is important that the dampers and actuators are selected, sized and operated correctly.

**I-C. Damper Selection**

Traditionally, little attention is given to the selection of the dampers that comprise the economizer. What is even worse is that the selection of the actuators that operate the dampers is based upon one criterion only, and that is that they provide sufficient torque to operate the dampers. The accuracy of the control is rarely considered. Without accurate damper positioning, the economizer will not function correctly, and both the indoor air quality and comfort is compromised.

The following text discusses the importance of selecting and sizing the dampers for correct operation.

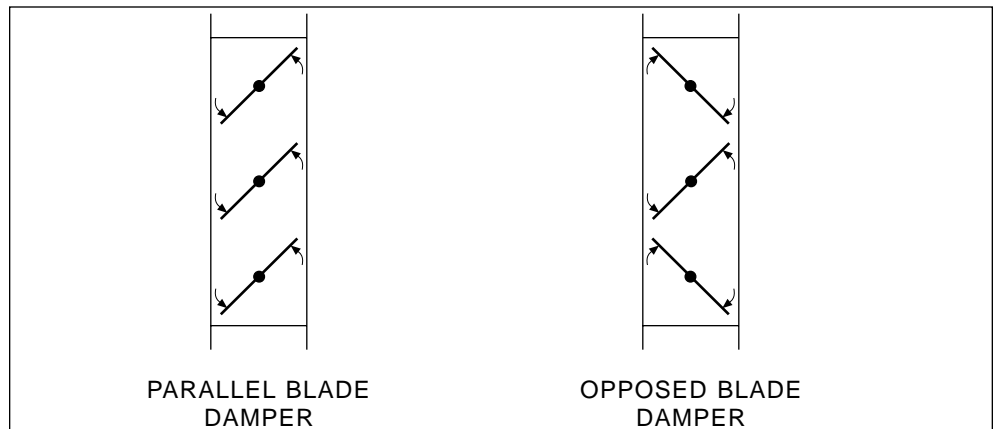
**II. DAMPER SELECTION**

**II-A. Opposed and Parallel Blade Dampers.**

In HVAC installations two different types of rectangular dampers are used to modulate air flow. These are parallel and opposed blade dampers.

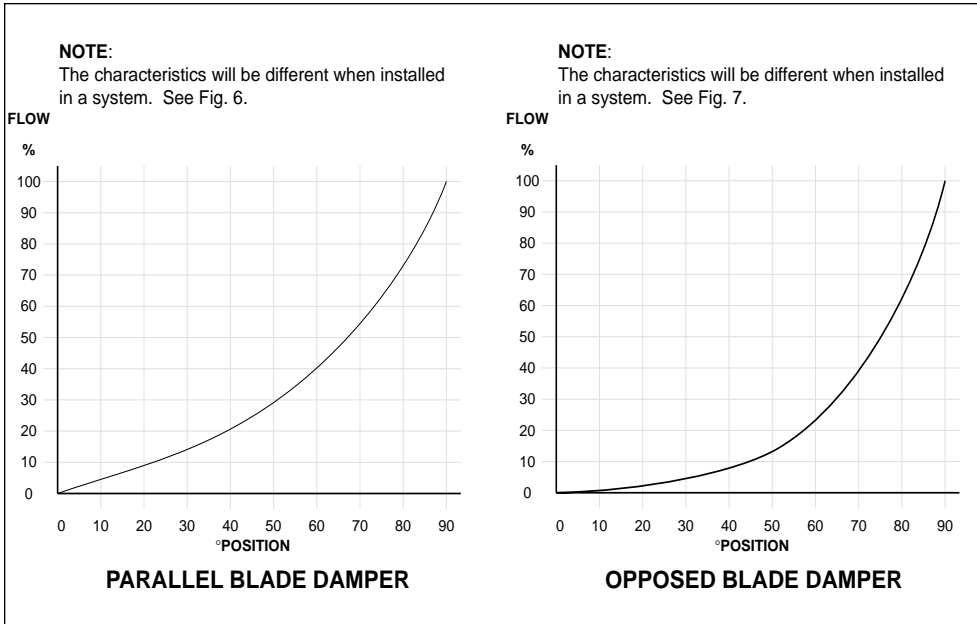
Parallel blade dampers are constructed so all the blades move in the same direction and in parallel. See Fig 2.

Opposed blade dampers are constructed so blades next to each other move in opposite directions. See Fig. 3.

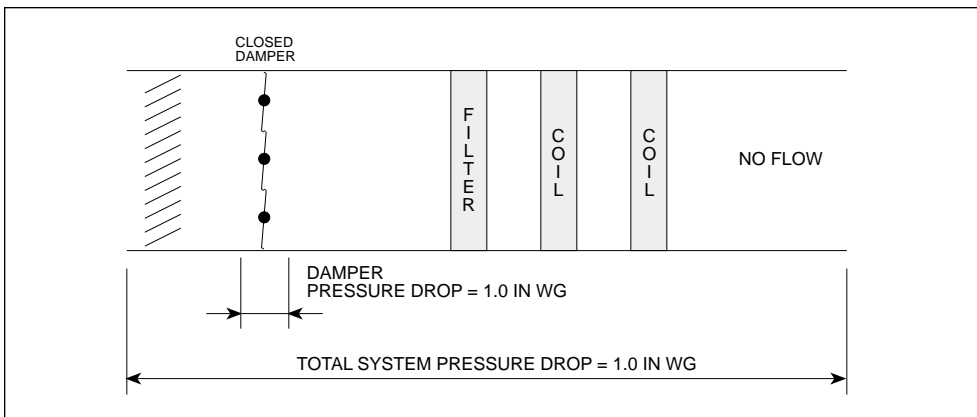


**Fig. 2**

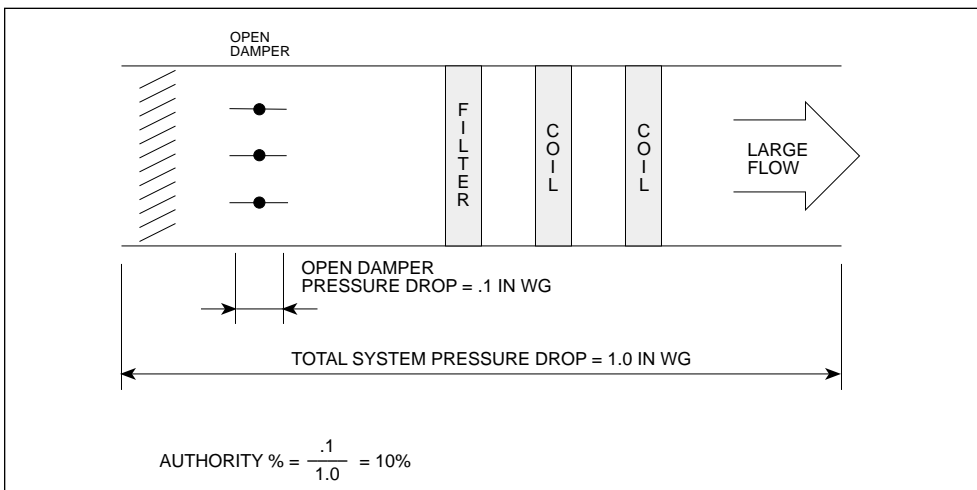
**Fig. 3**



**Fig. 4 - Inherent Characteristics of a Parallel and Opposed Blade Dampers**



**Fig. 5A**



**Fig. 5B**

## II B. Flow Characteristics

The two types of dampers have different “inherent flow characteristics”. This can be illustrated by a curve that shows the relationship between the flow rate and the position of the blades.

Fig. 4 shows the inherent flow characteristics for both parallel and opposed blade dampers. Notice that neither damper has a linear characteristic.

Opposed blade dampers give a very slow increase in the flow when the damper begins to open.

Parallel blade dampers have an inherent curve that is not as pronounced, so the flow increases more rapidly when the damper begins to open.

It is very important to realize that the inherent curves are measured under laboratory conditions, with a constant differential pressure across the damper. (In a real installation the curves will be distorted. See Fig. 6 and 7.)

## II-C. Damper Authority

When installed in a system, the damper is not the only device which affects the flow. Other parts of the system, such as the duct work, filters, coils, etc., will also restrict the flow. The result is that the damper will not control the flow in accordance to its inherent flow characteristics.

When the damper is closed (See Fig. 5A), the full differential pressure will fall across the damper, but when it is open (See Fig. 5B) the pressure drop across all other parts will be large, leaving little pressure drop across the damper.

The pressure drop across the damper changes as the damper is operated from closed to open. This distorts the flow characteristics curve. When the damper begins to open, the differential pressure is high, and the flow increases at a higher rate than what the inherent curve suggests. When the damper is almost fully open, the pressure drop across the damper will be small,

compared to the total pressure drop, so if the damper moves, for example, from 80 to 90° opening, the flow will change very little.

A damper which is sized so it has a small resistance when fully open in comparison to the total system resistance, will have a small influence (authority) on the flow when it operates near the fully open position.

The resistance of the fully open damper can be expressed as a percentage of the total system resistance and is called “Damper Authority” or “Characteristic Ratio”.

Damper Authority % = 
$$\frac{\text{Open Damper Resistance}}{\text{Total System Resistance}} \times 100\%$$

The resistance is a pressure drop, so we can also write:

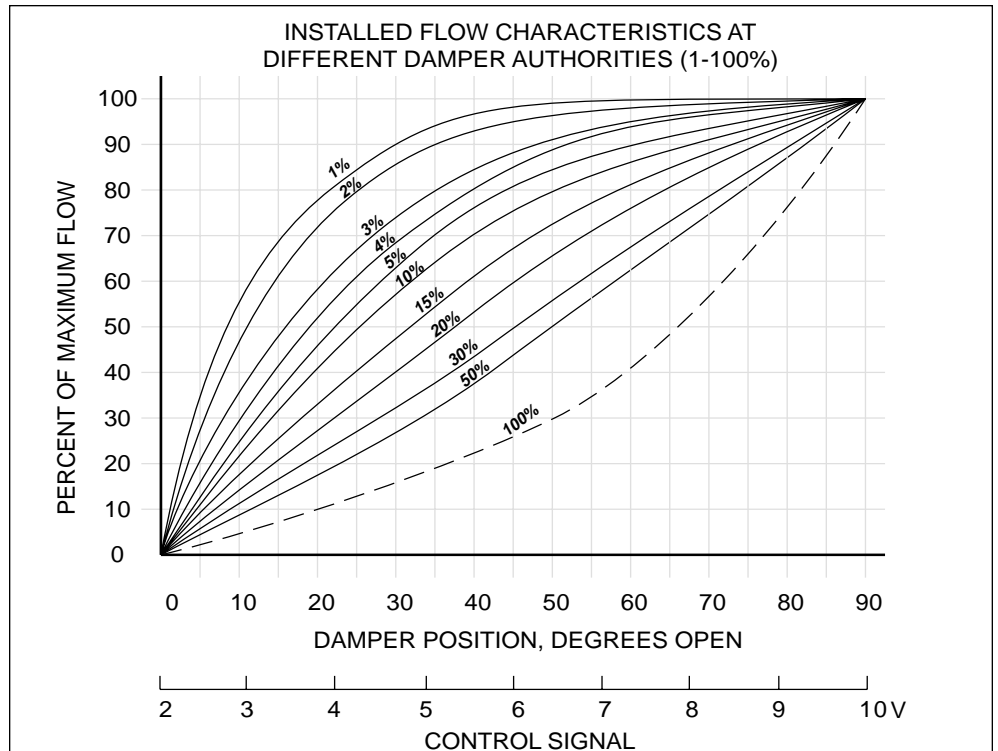
$$\frac{\text{Open Damper Pressure Drop}}{\text{Total System Pressure Drop}} \times 100\%$$

The pressure variation across the damper distorts the inherent characteristics curves. Instead, we will get an “Installed Damper Characteristic”, which depends upon the Damper Authority. See Fig. 6 and 7. If the authority is 100%, then we will get the inherent characteristic, but this will rarely happen in a real installation. Instead, a much lower number (Ex. 1 - 10%) is realistic. As can be seen in Fig. 6 and 7, at an authority of 1%, the curve deviates greatly from the inherent curve (100%).

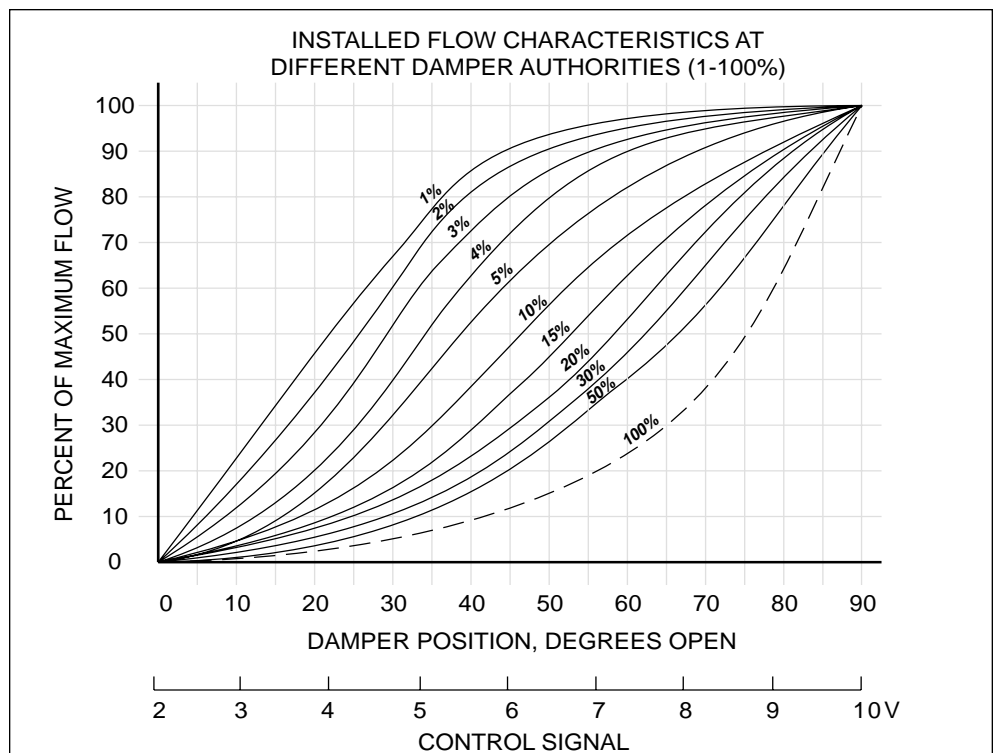
It is very important to realize that the “Total System Resistance” or “Total System Pressure Drop”, only relates to the part of the system where the flow is controlled by the damper. See Fig. 8. The flow downstream of the mixing plenum (point A) is not controlled by the OA damper (it is constant, at least in theory). The OA damper only controls the flow through the weather louver, the damper and the OA duct work. Therefore the authority of the OA damper is determined by the pressure drop across the OA damper as a percentage of the total differential pressure between OA and point A.

The total system pressure drop for the OA damper is measured between OA and Point A. The RA damper is measured between Point B and Point A. The EA damper is measured between Point B and EA.

If a single damper is used to control the flow through an air handler and duct work, then the total system pressure drop is the sum of the pressure drops in all the parts. (See Fig. 5A and B)



**Fig. 6 - Parallel Blade Damper Flow Characteristics**



**Fig. 7 - Opposed Blade Damper Flow Characteristics**

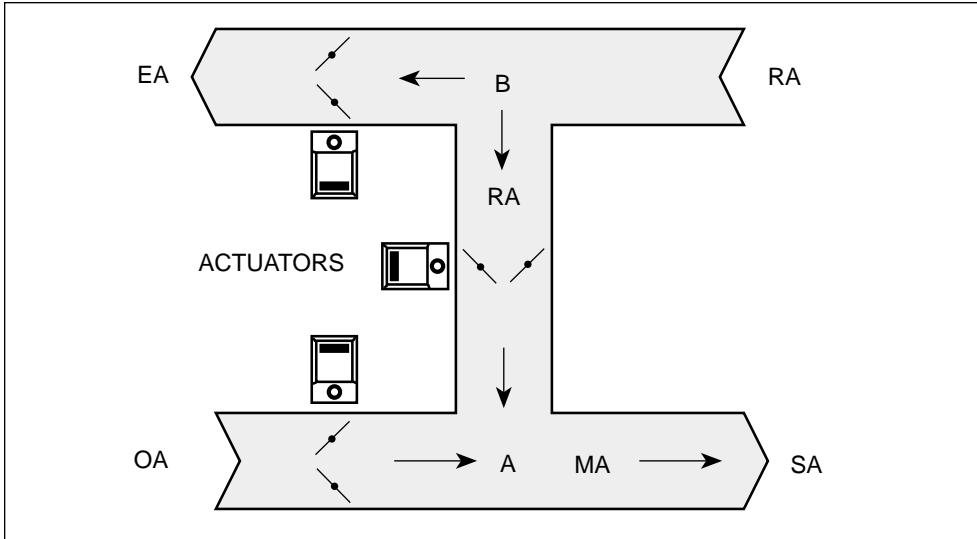


Fig. 8 - Economizer System

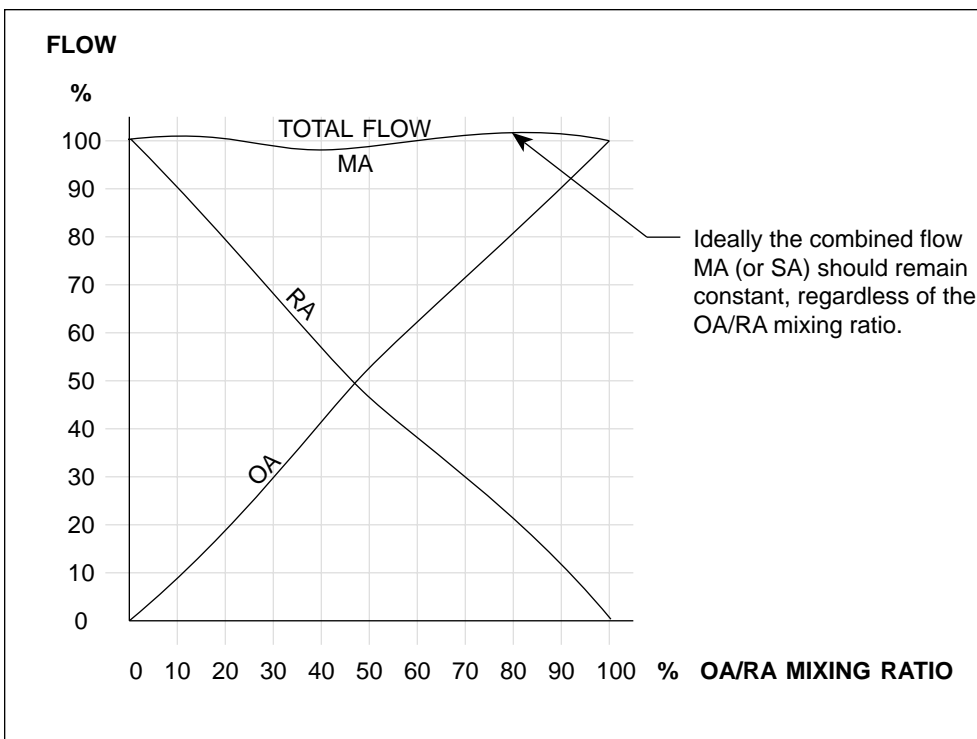


Fig. 9 - Ideal Function

**II-D. Combined Flow**

The sizing of the OA, RA and EA dampers installed in an Economizer is very important because it determines the installed damper characteristics. If the dampers have been properly sized, their characteristics will complement each other so the total flow will be constant. See Fig. 9. The pressure at points A and B will remain constant regardless of the OA/RA mixing ratio.

See Fig. 10. The OA damper modulates the OA flow. When it is fully open, a large portion of the differential pressure will fall across the weather louver and the OA duct work, resulting in a relatively small differential pressure across the OA damper. When the OA damper is completely closed, the full differential pressure will fall across the OA damper. The authority of the OA damper is the differential pressure across the damper when it is fully open, as a percentage of the differential pressure between point A and the atmosphere (OA). The calculation of this percentage number is shown as an example in Fig. 10.

The authority of the RA damper is the differential pressure across the damper, when it is fully open as a percentage of the differential pressure between points A and B.

The authority of the EA damper is determined by the fully open differential pressure and the differential pressure between point B and the atmosphere.

Unfortunately, most dampers are poorly matched. See Fig. 11. This results in a non-linear OA/RA mixing ratio, a variable combined flow (MA) and pressure variations in the mixing plenum, which may affect the building pressure.

**III. ADDITIONAL CONSIDERATIONS**

**III-A. Economizer Systems**

Most economizer systems have one outside air (OA), one return air (RA) and one exhaust air (EA) damper. The dampers are usually operated in unison, so as the OA and EA dampers close, the RA damper opens. The dampers should be sized so they complement each other, so an increase in the OA flow is matched by an equal decrease in the RA flow. Now, the total flow should be constant, regardless of the mixing ratio between OA and RA flow, and the resistance to the flow will be constant, so the pressure in the

mixing plenum will stay constant. Unfortunately, this is extremely hard to accomplish, because the dampers have a non-linear characteristic. There are also other considerations that have to be taken into account, when the dampers are sized and selected.

The indoor air quality is very dependent upon the amount of “fresh” outside air that is introduced into the building. The economizer varies the mixing ratio of outside and return air to meet the varying conditions. At 100% outside air, maximum free cooling is provided, and when the load changes, the mixing ratio is changed until the outside air volume is reduced to a specified minimum volume which satisfies the indoor quality requirements. In many systems, the economizer is at the minimum position, and provides the minimum volume of outside air when there is a need for mechanical cooling or heating. At intermediate load, the mixing ratio is changed to maintain a constant mixed air (MA) temperature.

Minimum OA CFM can be set a number of ways.

A pitot-tube traverse is usually the most accurate if a 100% effective duct length is available to get a velocity pressure profile uniform enough for good readings.

Totalling outlet CFM is possible but error due to 5 - 15% duct leakage occurs.

As a check to one of the above methods, the following formula can be used:  $TMA = TOA (\%OA) + TRA (\%RA)$ ; where TMA = mixed air temp., TRA = return air temp., TOA = Outside Air Temp., % OA = % OA volume, % RA = % RA volume. If % OA = 10%, then % RA = 100-10 = 90%; TOA = 60°; TRA = 70°; then TMA = 69° within the error range, ± 2°, of the sensors. It is important to use accurate temperature sensors.

Some close coupled equipment (rooftop units in particular) are difficult to control properly. The lack of a return fan or exhaust often leads to OA entering from the so-called EA damper until the RA damper is nearly

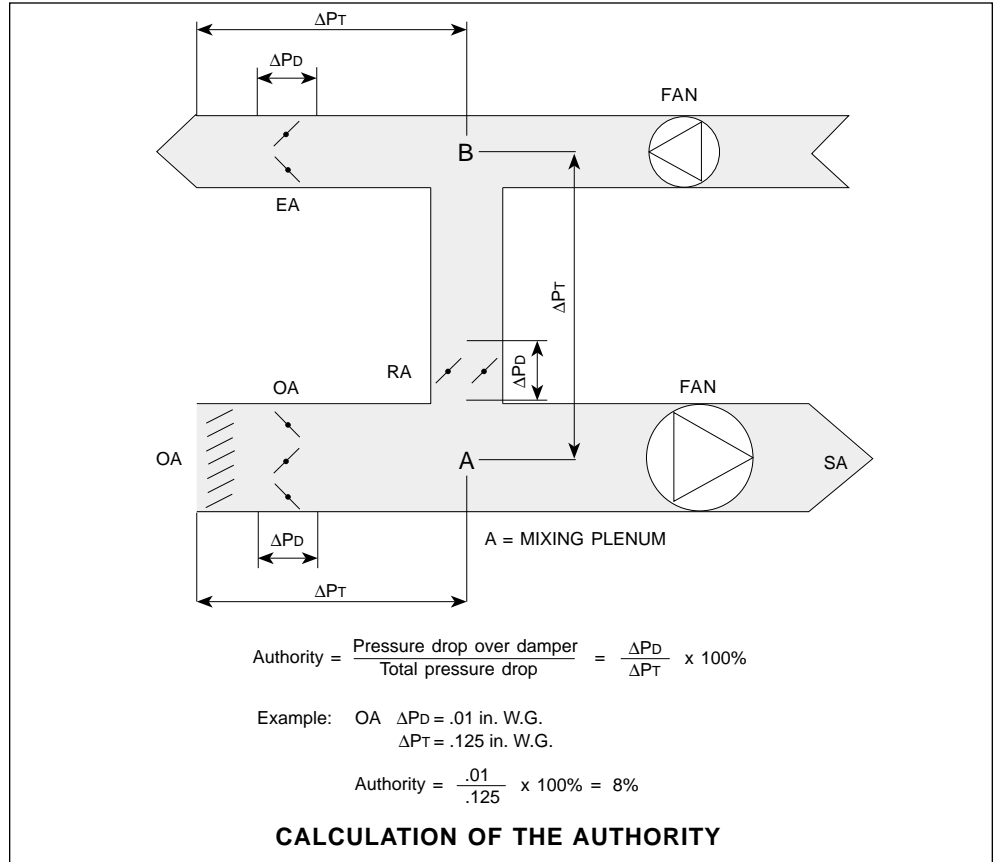


Fig. 10

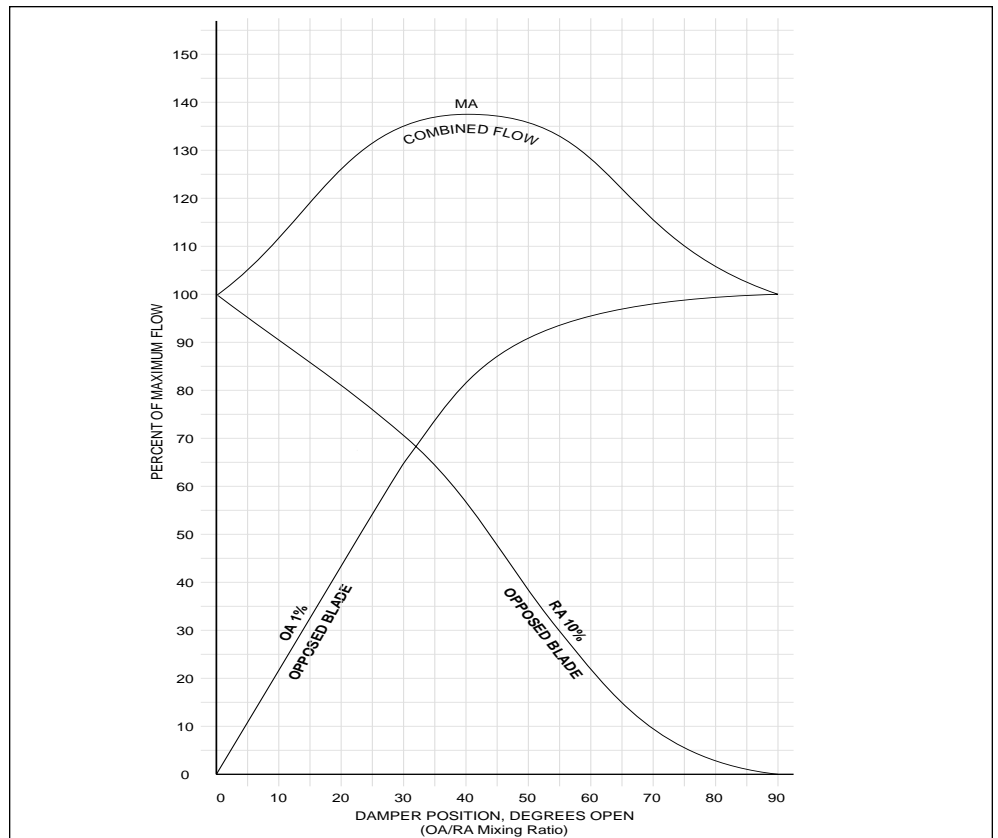
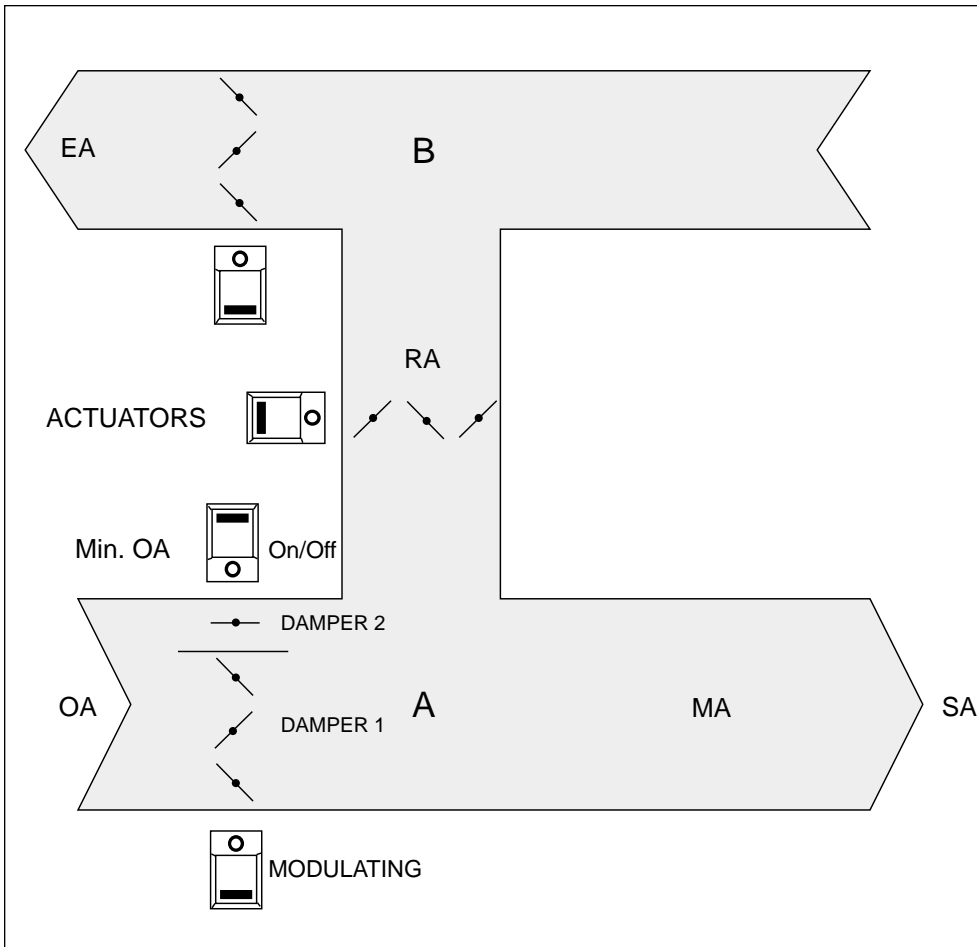


Fig. 11



**Fig. 12**

and the economizer is just one of them. However, if the economizer system can not maintain a constant pressure in the mixing plenum (*Point A in Fig. 12*), the pressurization of the building will be affected.

### III-C. Mixed Air Temperature Control

The mixed air temperature control is accomplished by varying the mixing ratio between the outside and return air. There are many things that can complicate this function and cause stability problems.

If the dampers are poorly matched, the mixing ratio will not change as a linear function when the dampers are operated. An additional complication is that the pressure in the mixing plenum will not stay constant. The result of this is that at some portions of the damper movement, there will be a large change in the mixed air temperature, while at other portions the change will be quite small. This non-linear function causes stability problems for the mixed air temperature control.

### III-D. Actuators - General

When the fans are running, the dampers are subject to forces which increase friction. The resistance created by this friction must be overcome by the actuators. There are also dynamic forces that act upon the damper blades, and tend to turn them either clockwise or counterclockwise, depending upon the position of the blades. The actuators must be able to overcome these forces to position the dampers accurately. See Fig. 17.

Usually, the actuators respond to a variable analog control signal, which either is pneumatic (3...15 psi) or electronic (2...10 V).

Ideally the dampers should be repositioned in direct proportion to the control signal, and follow a "Nominal Signal/Position Curve". This is usually not the case, because of the hysteresis in the actuators and linkage.

closed. The building overpressurizes during most of the year.

The minimum outside air volume is accomplished by limiting the modulation of the dampers to a minimum position which provides the desired outside air volume. It is very important that this position is controlled accurately because a small positioning error will have a disproportionately large effect upon the minimum outside air volume. An alternative solution is to use two OA dampers. One is modulated in unison with the RA and EA dampers, as described above. The other damper is smaller and is opened when the fan is running. This damper supplies the minimum OA volume. See Fig. 12.

### III-B. Building Pressure

No building is completely tight. Therefore a slight positive pressure is required, in order to prevent any infiltration of outside air into the building. Leakage of air into the building can cause severe problems with the indoor climate and the building structure, especially in the heating season.

The pressurizing of a building depends upon a number of factors,



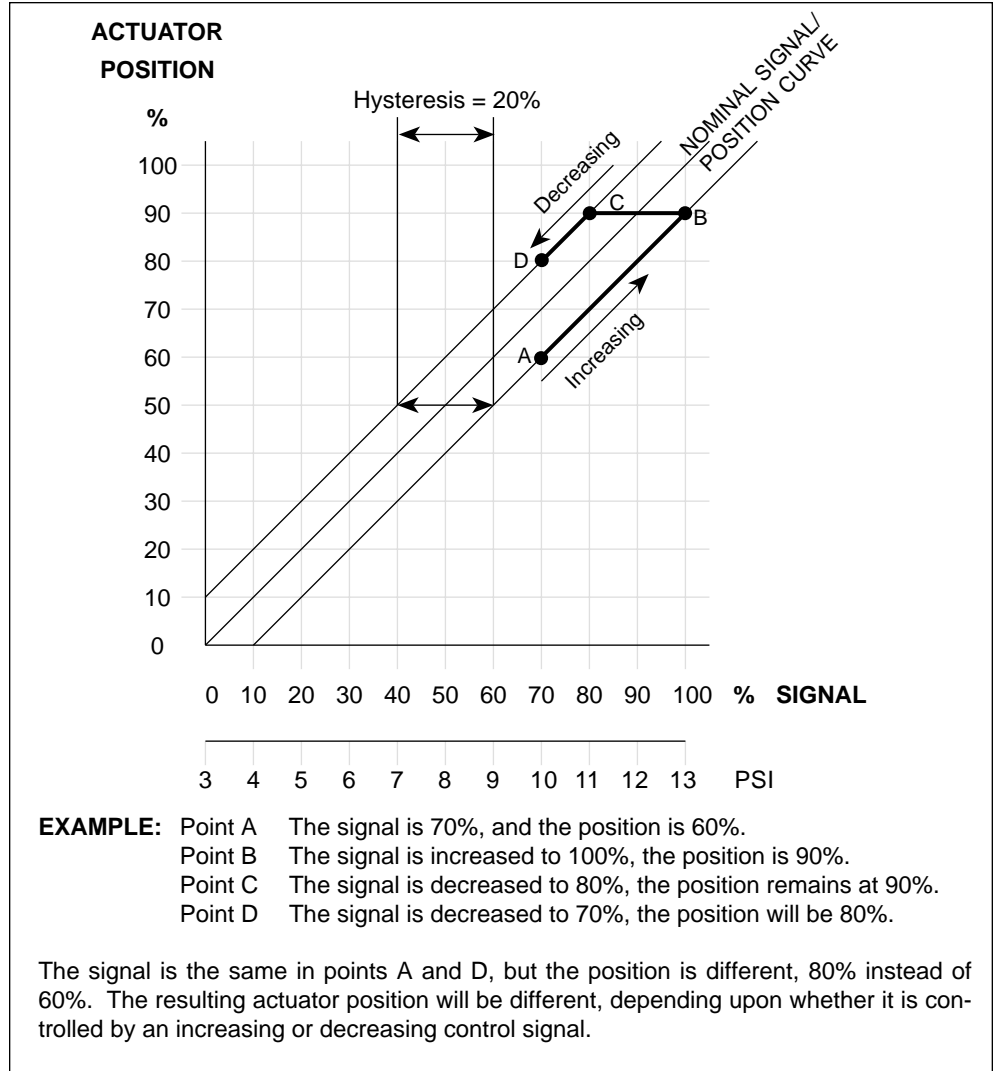
**III-E. Hysteresis**

See Fig. 13. All actuators have some hysteresis, which means that there is one position/signal curve for increasing signals, and a slightly different curve for decreasing signals. The result is that the position will be slightly different if it is an increasing or decreasing signal.

The control signal has to be changed by a certain value in order to reverse the movement of the actuator. This “dead zone” is the hysteresis, and often is expressed as a percentage of the control signal range. Most actuators are connected to the dampers via a linkage, which has an inherent play (slack). The actuator can move back and forth a few percent before the damper begins to move. This is also a form of hysteresis, which adds to the hysteresis of the actuator, so the total hysteresis can be quite large.

The hysteresis creates two serious problems:

1. It adds to the stability problems of the mixed air temperature control.
2. It makes the positioning of the actuators very inaccurate. This is especially serious with respect to the minimum position of the outside air damper. If the control signal is *increased* from zero (closed OA damper) to the value that represents the Min. position of the OA damper, a lower than desired Min. position will result. If the control signal is *decreased* from a high value to the value that represents the Min. position of the OA damper, a higher than desired Min. position will result. This difference in the Min. position, depending upon if it has been approached from above or below, will have a very large impact upon the Min. outside air volume. See Fig. 16.



**Fig. 13**

The hysteresis must not be confused with the “Resolution”. Resolution is the smallest increment the actuator will move, when fine and slow changes in the control signal is made.

The fact that in some applications, actuators can modulate the dampers very smoothly, as long as the control signal is continually changed in the same direction, is not any proof that there is no hysteresis. The hysteresis will only reveal itself when the movement of the damper is reversed. Therefore the hysteresis should be measured by first increasing the signal to, for example, 40%, and then decreasing the signal very carefully, until the damper (not only the actuator) just begins to move. The difference in the signal is the hysteresis, so if the damper begins to close at 25% signal, the hysteresis is 40 - 25 = 15%. Of course, this test must be done with the fans running, applying forces to the damper which the actuator must overcome. Hysteresis should be measured at different points of damper movement, with a special emphasis on the Min. OA position.

**III-F. Accuracy**

The combination of poorly matched dampers and total hysteresis in the linkage and actuators can make stable control of mixed air temperature very hard to accomplish, even if advanced controllers are used.

If the minimum position of the OA damper is not controlled accurately, the Min. OA volume will be smaller or larger than the required

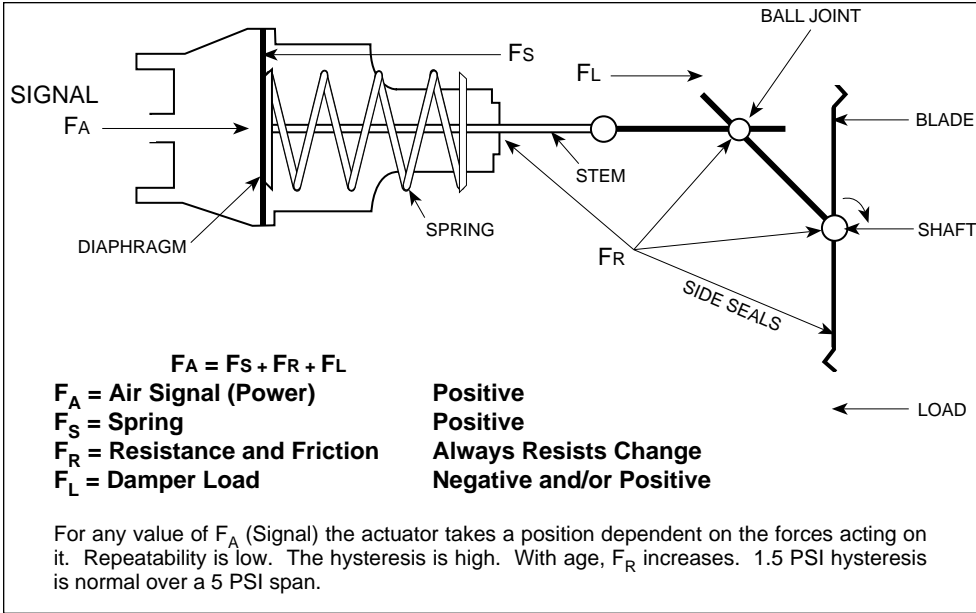


Fig. 14

value. A lower volume will result in a poor indoor air quality. A higher volume will result in needlessly high operating costs.

**III-G. Actuators - Pneumatic**

Pneumatic actuators are so common that we should study their function in detail.

They are reliable, have spring return function, but usually operate with a very high hysteresis. This is inherent to the design. See Fig. 14. The pressure of the control signal acts on the diaphragm and produces a force, which pushes out the stem and compresses the spring until the forces are in balance. The position of the shaft will change in proportion to the control signal. (The nominal signal/position curve).

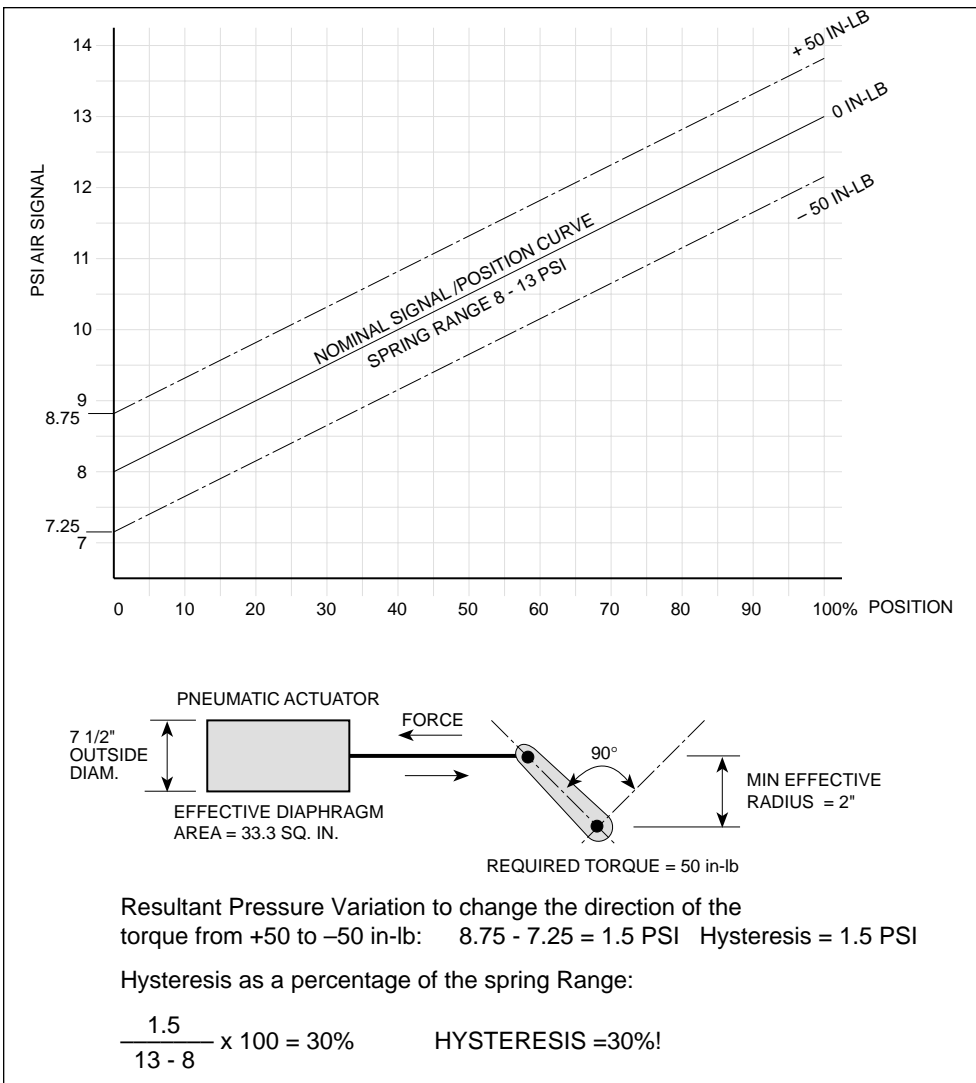


Fig. 15 - Typical Pneumatic Spring Range Shift and Hysteresis

However, in order to produce a net force at the output shaft, there must be an imbalance between the diaphragm and the spring. The force from the diaphragm must be stronger than the spring in order to produce a pushing force, and the force from the diaphragm must be less than the spring force in order to produce a pulling force. This deviation between the position and the nominal signal/position curve is called "spring range shift".

Fig. 15 shows a pneumatic actuator which is required to produce a clockwise (+) 50 in-lb torque to open a damper, and a counterclockwise (-) 50 in-lb torque to close it. The minimum effective radius of the linkage arm is 2". This means that the pushing or pulling force of the actuator is +25 lb. or - 25 lb. (Torque/Effective radius = Force.  $50/2 = 25$  lb.)

The outside diameter of this actuator is 7 1/2", which corresponds to an effective diaphragm (piston) area of approximately 33.3 sq. in.

When the signal pressure and the position are in balance, no net force is produced at the output shaft. This is represented by the "nominal signal/position" curve. In order to produce a 25 lb. force the signal pressure has to be higher or lower than the nominal signal/position curve.

The resultant pressure variation is 25 lb./33.3 sq. in. = 0.75 psi. Therefore, in order to change from +50 in-lb to -50 in-lb torque, the total variation has to be  $2 \times 0.75 = 1.5$  psi. This is 30% of the spring range of a typical pneumatic actuator (8 to 13 psi).

The hysteresis and spring range shift in an actual installation depends upon how generously the pneumatic actuator is sized, in comparison to the required torque. If the actuators are oversized, the hysteresis will be less. The recommendation of the pneumatic actuator manufacturer's is typically 1 1/4 - 2 in-lb for each square foot of damper area. This is less than adequate. The resulting hysteresis can be 12% or more. See Fig. 16.

**III-H. Positioner**

The accuracy of pneumatic actuators is considerably improved if they are provided with positioning relays ("positioner"). A positioner compares the actual position of the actuator with the control signal, and changes the pressure to the diaphragm until the actuator assumes a position that corresponds to the control signal. This reduces the hysteresis to about 1/4 psi, which can be 2 1/2 - 5%, depending upon the operating range. However, frequent recalibration is needed to maintain the accuracy.

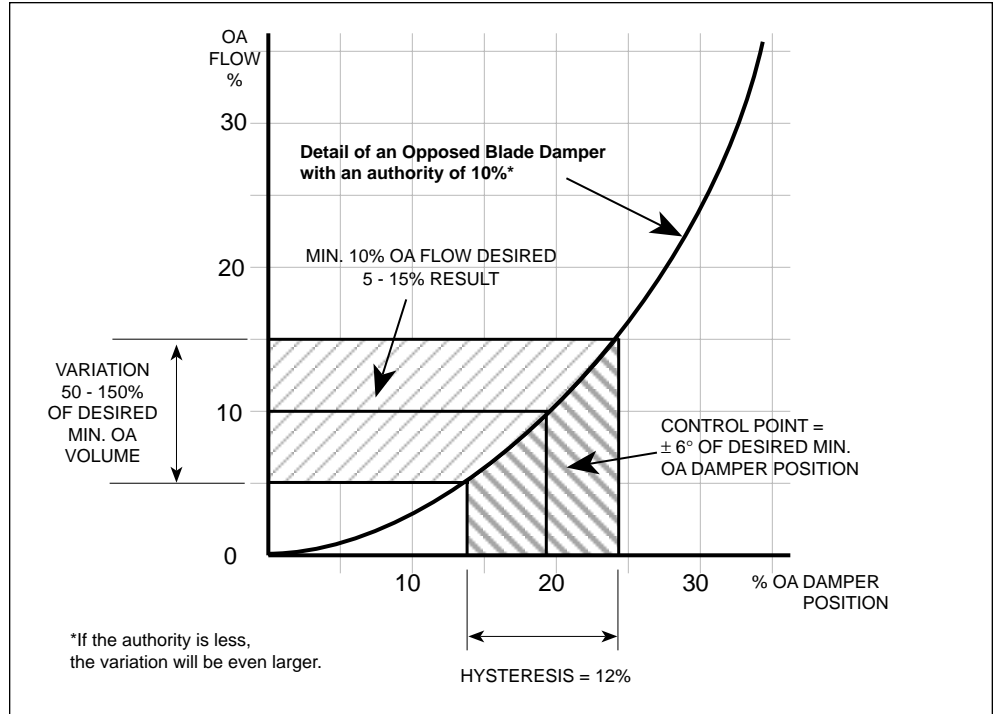
The additional cost of the positioner, and its adjustment, must not be forgotten when comparisons are made between pneumatic and electric actuators.

**III-I. Torque**

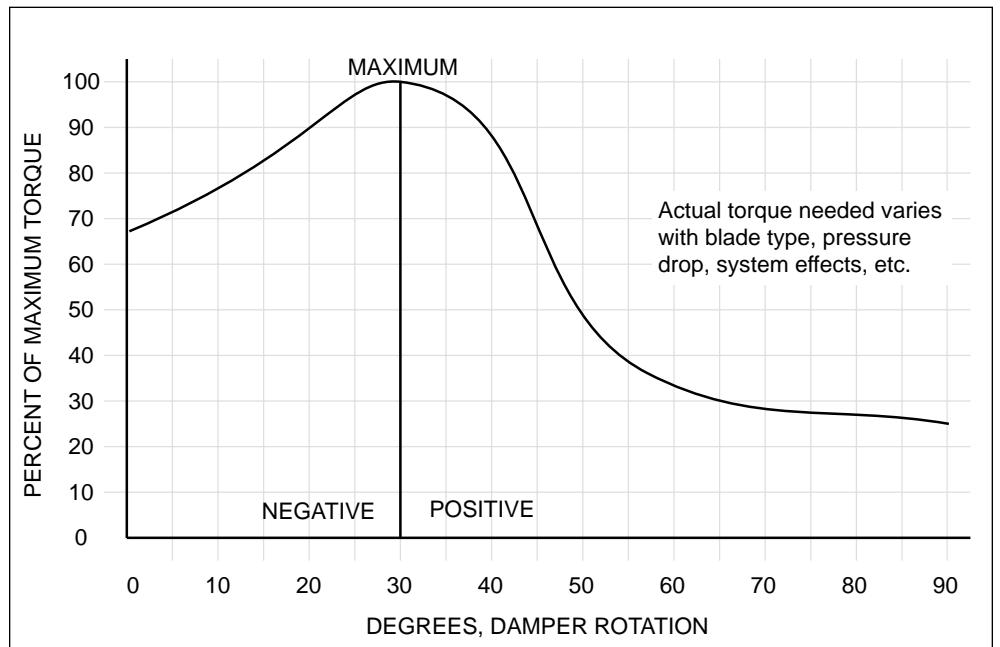
The torque that is required to operate a damper depends upon the size, type, quality and condition of the damper. It is also dependent upon the differential pressure and air flow. Contrary to popular belief, the maximum required torque is not always at the closed position. Typically, the maximum torque requirement is found at about 30% open position. See Fig. 17.

**III-J. Linkage**

The actuator is connected to the damper via a linkage, which has a couple of ball joints, pivots and other elements that have some play. The slack in the linkage can easily cause a 1 - 3% hysteresis, when the stress changes from a pulling force to a pushing force. This effect requires the actuator to move about 1 - 3% before the damper begins to move. The amount of hysteresis depends upon the condition of the linkage and how well it has been adjusted. If the linkage is improperly adjusted and the joints are worn, the hysteresis can actually be larger than 5%.



**Fig. 16 - Results of Hysteresis on Min OA Air Flow**



**Fig. 17 - Typical Torque Requirement**

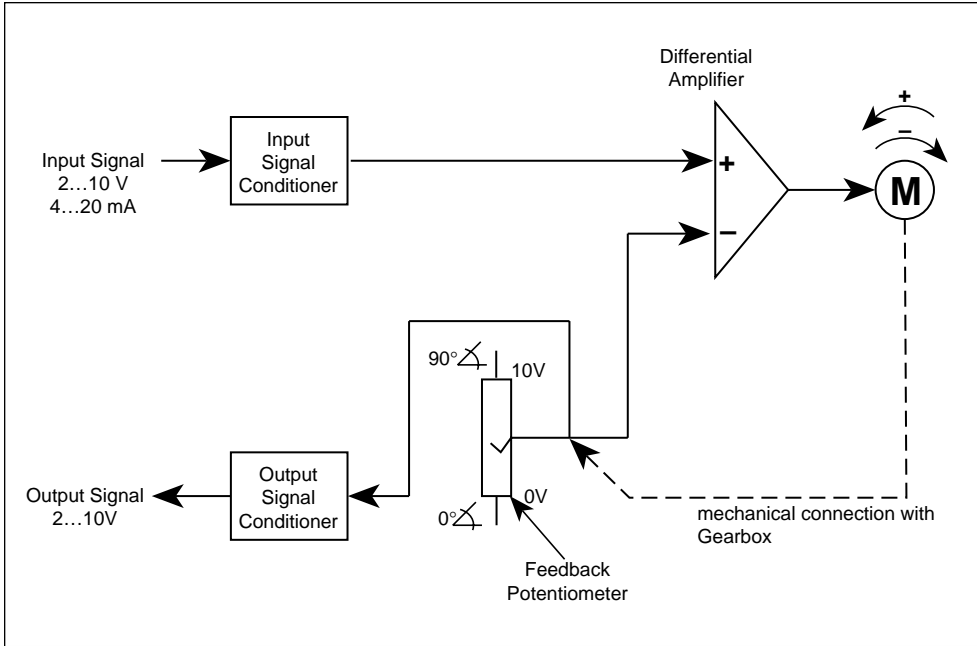


Fig. 18

### III-K. Actuators - Electronic

Electronic proportional actuators require both a power source, usually 24 VAC, and a control signal, usually 0 to 10 VDC or 4 to 20 mA. Their operation can be compared to a pneumatic actuator with a positive positioner. However, unlike its pneumatic counterpart, the electronic actuator requires no field calibration and usually no field maintenance. The position feedback is more precise than a pneumatic device because of a repeatable, geared, interface between the actual actuator position and its feedback monitoring system. The feedback signal is also usually available as an output from the actuator to either monitor the actuator position or as signal for part of a control sequence.

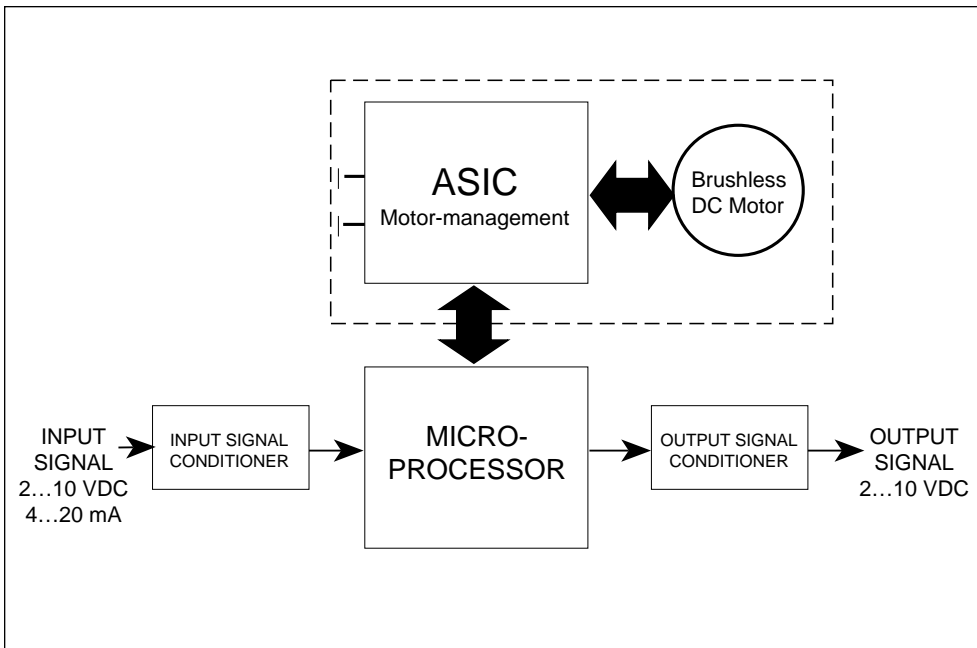


Fig. 19

Feedback can be generated by several methods. Fig. 18 and Fig. 19 show two of these methods. Fig. 18 shows a typical potentiometer circuit used to measure feedback. In this case, the signal from the potentiometer is fed into a differential amplifier along with the input signal. The differential amplifier looks at the difference between the input and feedback signal. It then gives a signal to move the actuator clockwise or counterclockwise until the feedback signal matches the input signal. Fig. 19 shows a newer method which uses microprocessor technology. In this case, a microprocessor communicates to an application specific integrated circuit (ASIC). The ASIC both controls and monitors a brushless DC motor. By monitoring the digital pulses generated at the brushless DC motor, the exact position of the actuator can be determined by the microprocessor. The microprocessor also allows for special control criteria to be used in either operational characteristics or input signal processing.

### III-L. Electronic Actuators - Conventional Crank Arm Type

Conventional electronic and electrohydraulic actuators typically have a small hysteresis of about 1%. These actuators are mounted to dampers in a similar manner as a pneumatic actuator, by the use of a linkage. This, as in the case of pneumatics, adds 1% to 3% of hysteresis to the system and care must be taken in its setup. Electrohydraulic actuators are not gear type actuators; they work similarly to a pneumatic actuator by building up pressure against a spring. Because they work against a spring they are subject to spring range shift.

**III-M. Electronic Actuators - Direct Coupled**

Direct coupled actuators, just as the crank arm type, have a hysteresis of about 1%. However, this style of actuator does not require the use of a linkage. Because of this, the additional hysteresis of a linkage is not present. Without a linkage between the actuator and damper, the damper position can be controlled more accurately and the actuator torque is transmitted more efficiently to the damper. Also, the installation time is dramatically reduced. The following table gives a comparison of several actuator/damper combinations and their relative accuracy.

**DAMPER POSITIONING ACCURACY**

	Pneumatic Without Positioner	Pneumatic With Positioner	Electronic w/ Linkage	Belimo Direct Coupled
Actuator	12% <sup>a</sup>	2 1/2 - 5% <sup>b</sup>	1%	1%
Linkage	1 - 3%	1 - 3%	1 - 3%	None
E/P Transducer	2%	2%	None	None
Total	15 - 17%	5 1/2 - 10%	2 - 4%	1%

<sup>a</sup> 30% if undersized.

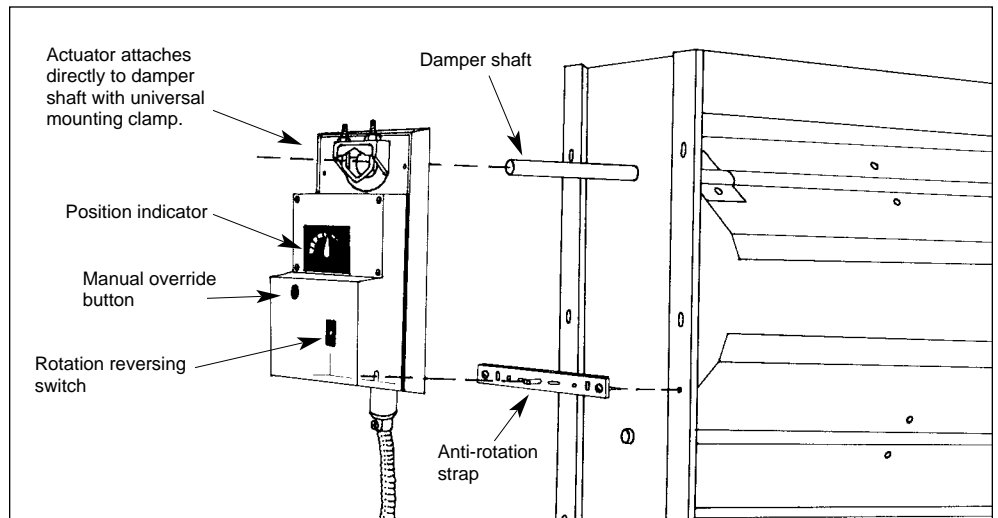
<sup>b</sup> Before calibration drift

As can be seen, direct coupled electronic actuators are far more accurate than any other type of actuator.

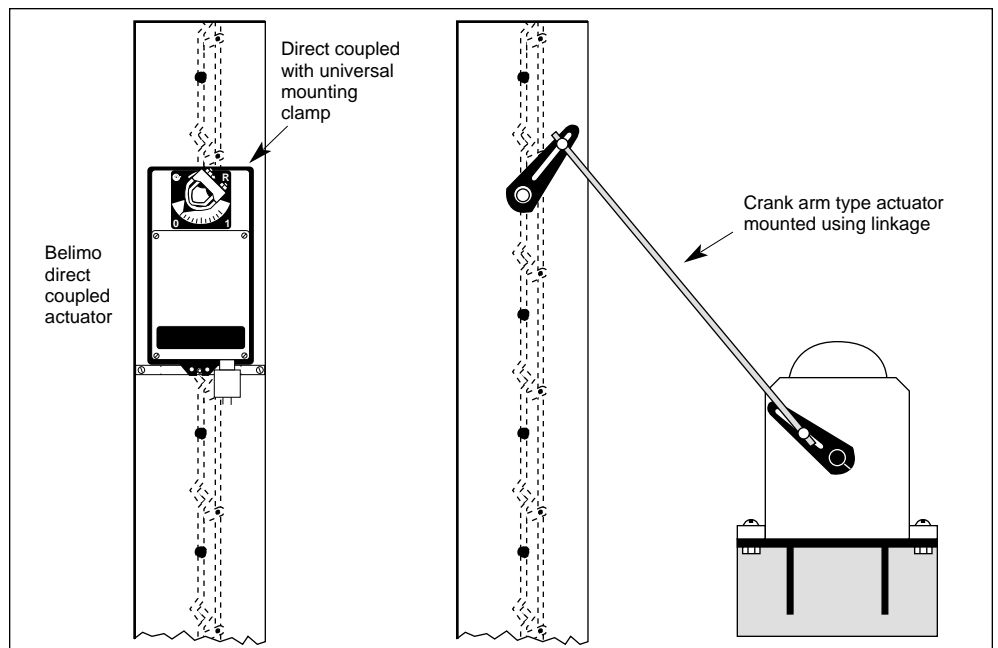
Fig. 20 shows an exploded view of a typical Belimo direct coupled actuator mounting. It is easy to see just how simple and straightforward this mounting method is. Direct coupled mounting greatly reduces installation time and lowers installation costs because fewer parts are needed.

Fig. 21 illustrates the difference between direct coupled mounting and mounting using linkage. Notice that the use of linkage often requires mounting the actuator on an independently located mounting bracket. The linkage itself generally consists of at least two crankarms connected by an operating rod attached to the crank arms with ball joints. Linkage systems can become quite complex and a number of geometrical issues must be addressed that can effect torque and response times. Please refer to Belimo's *Mounting Methods Guide*, Section 6, for more information about damper linkages.

It is also possible to mount a direct coupled actuator separately, and connect it to the damper via a linkage. About 20% of installations require this, but it should be used only if it is completely impossible to mount the actuator directly. The Belimo mounting instructions for linkages must be followed. If it is an old installation, replace the old ball joints with new ones that have the least possible play. It is important that the hysteresis be as small as possible.

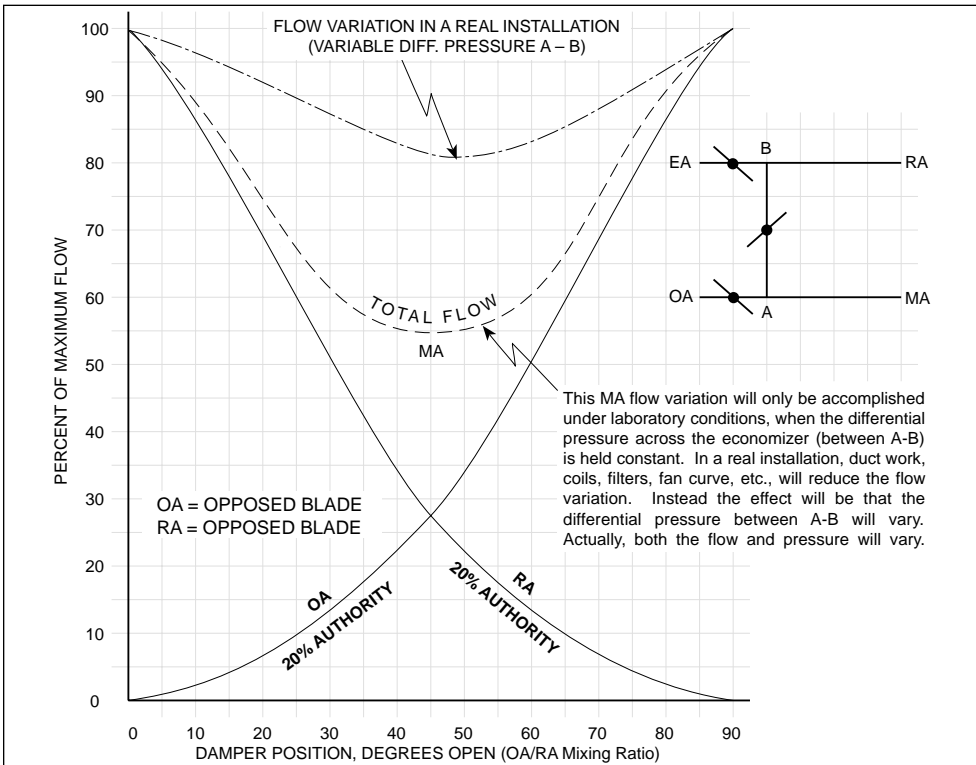


**Fig. 20**



**Fig. 21**

### IV. OPTIMIZING ECONOMIZER SYSTEMS

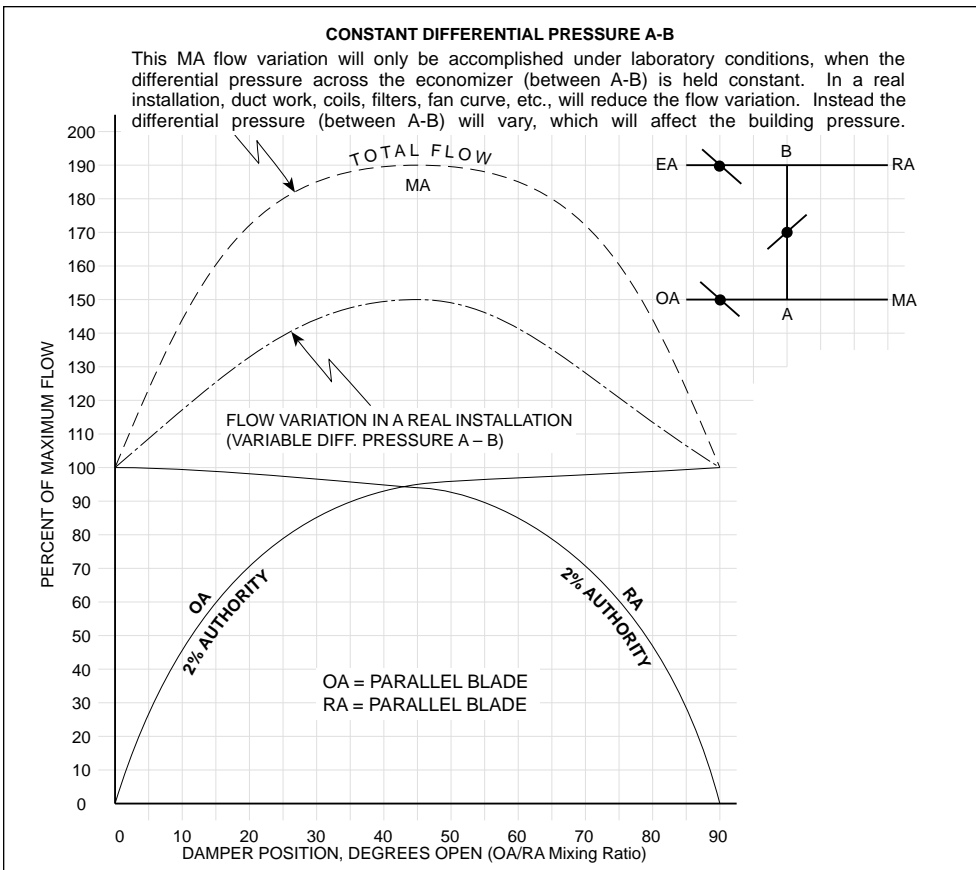


#### IV-A. Sizing of Dampers

The installed characteristics are determined by the authority of each damper. By sizing each damper correctly, the installed characteristics of the dampers can be chosen in such a way that they complement each other.

Fig. 22 & 23 show examples of dampers that are poorly matched. In Fig. 22 the OA and RA dampers are of opposed blade type, and have high authorities. The result is that the total air flow (MA) will not be constant. For example, when the dampers are in the mid position, the total flow will be much less than normal. In Fig. 23 the dampers are of parallel type and have a very small (2%) authority. The result is that the flow, when the dampers are in the mid position, will be much larger than normal.

Fig. 24 shows an example where the dampers have been selected and sized so their installed characteristics complement each other. The OA damper has opposed blades, and the RA damper has parallel blades. Both have an authority of 15%. As can be seen, the total flow (MA) remains rather constant regardless of the mixing ratio. As long as the variation in the total flow (MA) is less than 15%, the dampers can be regarded as well matched. Of course, each damper has to be sized with respect to the air flow and the available differential pressure. The OA damper should always be sized for a larger flow than the EA damper. The differential pressure across the RA damper is larger than across the EA damper, so the RA damper will be the smallest.



It is important to remember that there must be a slightly negative pressure at point A, in order for the outside air to enter the building. The pressure at point B has to be slightly positive in order for the exhaust to leave the building.

Very often the dampers are selected based upon the available duct size, with little concern for how well they are matched. In many installations,

the OA damper is installed next to the weather louver, and therefore has to be the same size to keep the velocity through the louver below 500 FPM to avoid snow and rain entering. This results in a very small damper authority and this makes the sizing of the RA damper very important and demanding.

**IV-B. Linearization**

See Fig. 6 & 7. If we study the installed flow characteristics of a damper at different authorities, we will find that the bottom part and top part of the curve is very non-linear. However, between about 10% and 80% flow, the characteristics are rather linear. This is true for all curves with authorities between 1% to 50%.

Most dampers are oversized, so there is no need to open them fully, in order to get the desired maximum flow. For example, if we limit the maximum opening of a damper to 80% flow, the non-linear top portion can be eliminated.

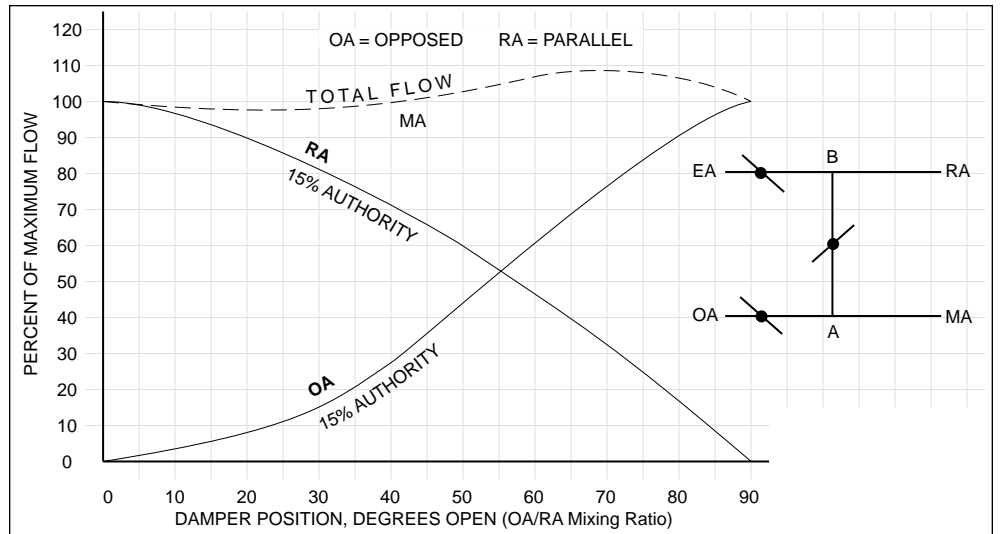
Outside air dampers must provide a specified minimum OA volume. Therefore, they must not be modulated below a certain minimum position. This is fortunate, because it eliminates the lower non-linear portion of the curve. Now, we can limit the operation of the damper to the linear portion only.

See Fig. 25, and the 1% authority curve (opposed blade). This damper is operated by a direct coupled actuator (2 to 10V). In order to open the damper to a 20% (Min. flow), the control signal has to be 2.8 V. In order to open the damper to an 80% flow, the control signal has to be 5.2 V. In other words, it takes only a 2.4 V change in the control signal to get a linear change from Min. to Max. flow. Because only a small portion of the operating range is utilized for this application, the resulting MA temperature can be erratic due to overcontrol.

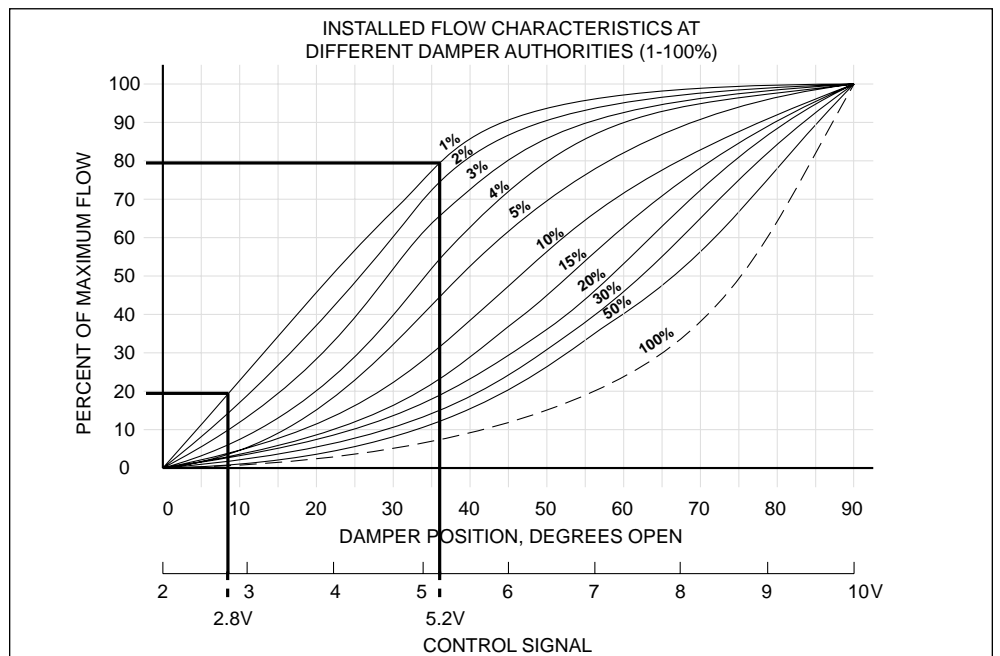
**IV-C. Range Controller**

Belimo offers a very useful device, called the SBG24 range controller (see page 18). It accepts the control signal (2 to 10 V) and modifies it so the damper is at the Min. position, when the control signal is 2 V, and the damper is at the Max. position when the control signal is 10 V. In other words, the full swing of the control signal (2 to 10 V) is utilized to vary the flow from Min to Max.

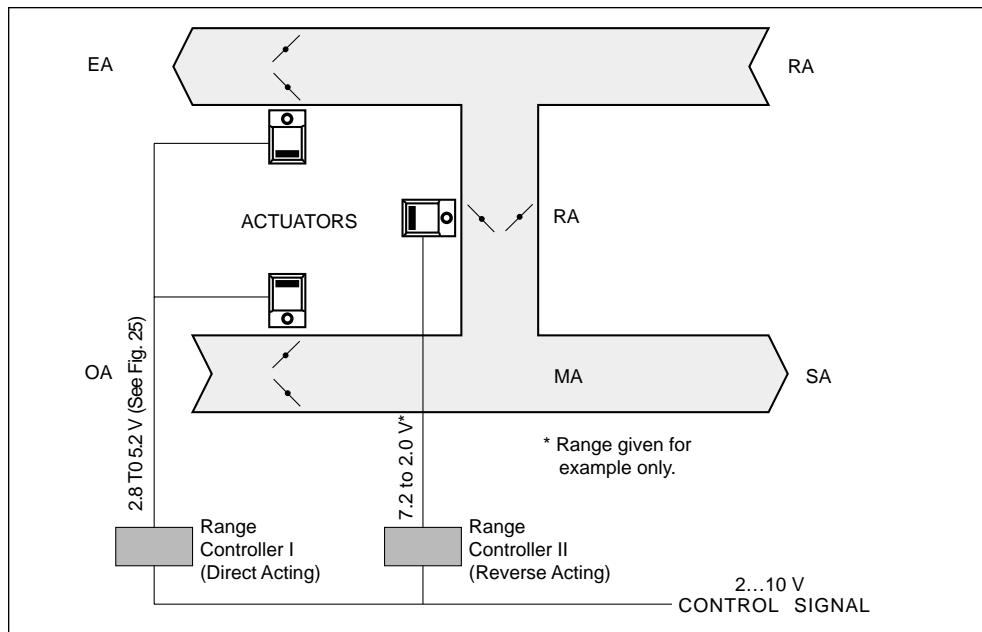
It is common practice to mechanically link the OA and RA dampers. This will save the expense of one actuator. Unfortunately, there are a couple of serious disadvantages associated with this. The most obvious problem is that the linkage will add a hysteresis to the operation of the RA damper. An even more serious problem is that the dampers have to be selected very carefully, so they are well matched. Otherwise the mixing ratio will not be controlled in a linear way, the total flow will not be constant and the pressure will vary. Fig. 22, and Fig. 23, are examples of poorly matched dampers. Fig. 24, is an example of correctly matched dampers.



**Fig. 24 - Example of Properly Matched Dampers**



**Fig. 25 - Installed Opposed Blade Damper Flow Characteristics**



**Fig. 26**

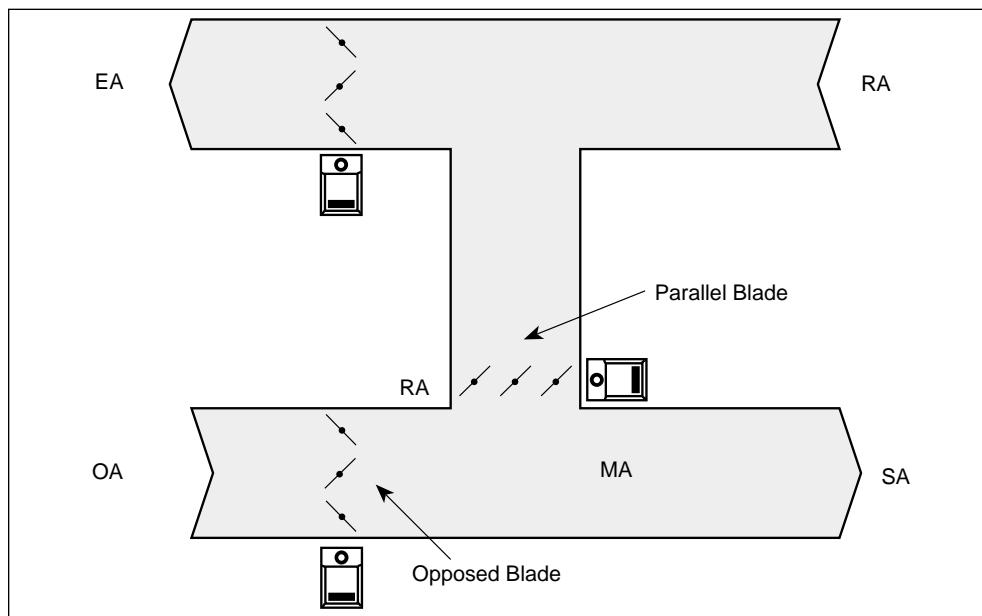
By using the range controller, the operation of the dampers can be modified so a more linear portion of the dampers are used. This also allows poorly sized dampers to be operated so they can more accurately complement each other. The full range of the control signal is utilized, and there will be a linear relationship between the OA/RA mixing ratio and the control signal. Also, the pressure in the mixing plenum will be constant.

See Fig. 26. Each of the dampers has its own actuator, so they can be operated independently of each other. The OA and EA damper actuators are connected to the same range controller. The RA damper actuator is connected to a separate range controller.

It is possible to duplicate the function of the range controller with the software of a DDC system. This is acceptable, but it is not necessarily a cost saving, because an additional analog output is needed. Another problem is that the fine tuning of the range controller should be done in conjunction with the balancing, and it is hard for the balancing contractor to access the DDC controller.

For a detailed description of the Range Controller, see the catalog sheet for SBG 24.

It is possible to duplicate the function



**Fig. 27**

#### IV-D. Choice of Dampers

Fig. 27 shows an economizer with OA and EA dampers of opposed blade type. The RA damper has parallel blades, mounted so the air flow is deflected up against the OA damper for good mixing. (This is only one of a number of possible destratification methods.)

Because in many installations, the OA damper has the same size as the weather louver, it will be oversized in comparison to the flow, which results in a low authority. Opposed blade dampers have characteristics that can control small air flows more accurately than parallel blade dampers. For example: in order to supply a 20% flow, an opposed blade damper, with an authority of

1%, has to open to an 8° position, while a parallel blade damper, with the same authority, should open to a 2.5° position. See Fig. 28 and Fig. 29. If the total hysteresis in the actuator and linkage is just 5°, the parallel blade damper may supply anything from 0% to 46% minimum OA volume (0° to 7.5° damper position). The positioning of an opposed blade damper is not quite as critical. A 5° error will result in a 8 to 30% deviation from the desired OA volume (3° to 13° damper position), so the opposed blade damper is a better choice when the OA damper is oversized and has a small authority. See also Fig. 16. A direct coupled actuator which has a 1% hysteresis will result in only a 2.5% deviation from the desired OA volume.

The range controller has the capability to adapt the control signal so the dampers are operated in such a way that they complement each other. This is done by limiting the damper movement to the linear portion only, and it makes the task of sizing the dampers less



critical. However, this does not mean that it no longer matters how the dampers are sized. If the dampers are correctly sized, the range controller only needs to make minor corrections, and a large portion of the damper movement can be utilized. However, if the dampers are poorly matched, a larger correction has to be used, and only a small portion of the damper movement can be used. The range controller will allow a great latitude when sizing the dampers, and even if the dampers are poorly matched, the function will be improved. However, the best result is achieved if the dampers are not excessively oversized.

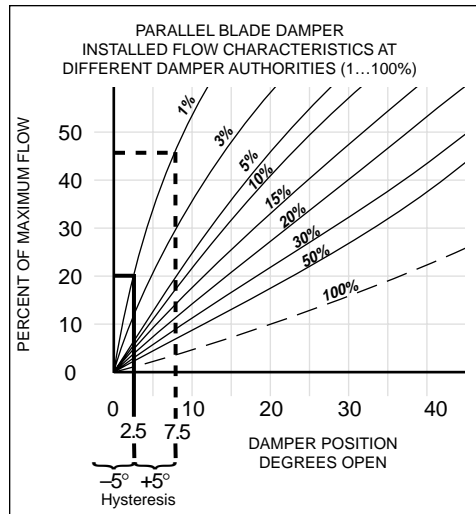


Fig. 28

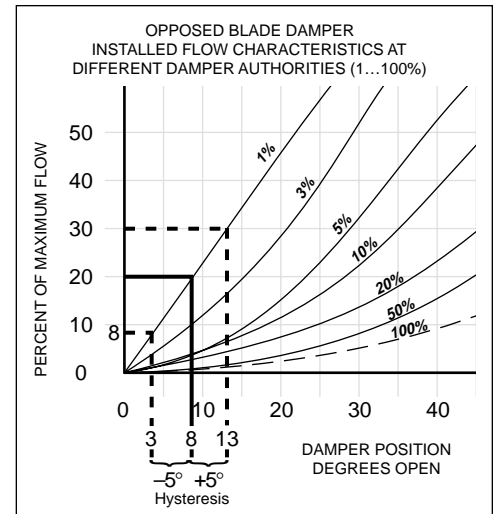


Fig. 29

## V. ADVANTAGES

### V-A. Direct Coupled Actuators

Electronic direct coupled actuators offer a tremendous advantage in that they are very accurate, and can position the dampers with the smallest possible hysteresis. If used in conjunction with the Range Controller, the dampers can be operated at a much superior level of control than would otherwise be possible.

### V-B. Range Controller

The Range controller offers the following advantages:

- The sizing of the dampers is simplified, because the dampers need not be perfectly matched.
- The mixed air temperature control is improved.
- The Min. OA position is set in the range controller.
- The total flow can be (balanced) adjusted by the range controller.
- Because the dampers are operated so they complement each other, the total flow will remain constant regardless of the mixing ratio.
- The pressure in the mixing plenum will remain constant.
- The range controller can be mounted adjacent to the economizer, so balancing is simplified. Flow measurements and adjustments can conveniently be done at the same location.

## VI. MODERNIZATION OF OLD INSTALLATIONS

When an old installation is modernized with a DDC system, it can be tempting to keep the old actuators if they still are working. This is always a very unfortunate decision, because of the poor accuracy offered by conventional actuators. The full benefits of the DDC system will not be realized, because the dampers cannot be controlled accurately.

Most existing installations have problematic damper control, which would benefit tremendously if the old actuators were replaced with direct coupled actuators and range controllers, and a recommissioning of the OA CFM is performed.

## VII. SUMMARY

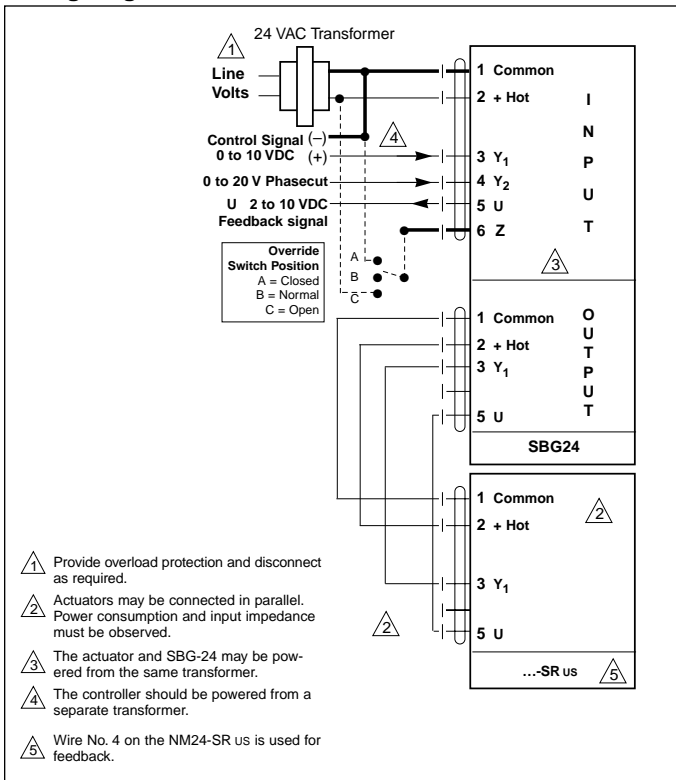
This guide has introduced a number of concepts, but is not a complete discussion. The importance of sizing and matching the dampers have been explained, with respect to the authority and other control aspects. However, for the final calculation and sizing of the damper, we refer to the damper manufacturer's tables, charts and instructions.

The range controller simplifies the sizing, and makes it possible to adjust for the "as built" conditions.

Finally, it cannot be emphasized strongly enough that the accurate and hysteresis free operation of the direct coupled electronic actuators is of the greatest importance for the economical operation of air handling systems.



## Wiring diagram



## Application

The SBG24 range controller is an interface device used between controller and damper actuator. It is used to compensate for the non-linear control characteristics of dampers due to their damper authority.

## Operation

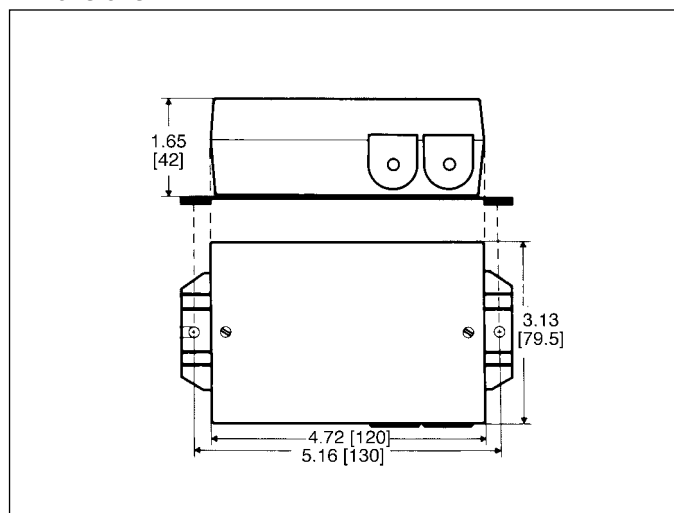
The SBG24 is designed to rescale the control output to the actuator. The maximum and minimum damper position can be set in the SBG24. The controller output signal (2 to 10 VDC, 4 to 20 mA, or 0 to 10 V phasecut) then modulates the actuator between the maximum and minimum set limits. By only modulating between these set limits, the damper typically can be controlled more in the linear portion of its damper authority curve. By the use of a SBG24 on both the outdoor air and return air dampers in an economizer system, a single controller output can more accurately position these dampers so the change in flow of one damper is off-set by an equal change in the other.

Overrides can also be used to make the dampers go to either a fully open or closed position.

**Note:** For an explanation of damper authority, see Belimo "Damper Application Guide 5.4."

Technical Data	SBG 24
Power supply	24 VAC $\pm$ 20% 50/60 Hz
Power consumption	1W without actuator
Transformer	1.5 VA without actuator
Electrical connection	terminals
Control signal Y	Y <sub>1</sub> 0 to 10 VDC Y <sub>2</sub> 0 to 20 V phasecut
Input impedance	100 k $\Omega$ (0.1 mA) 8 k $\Omega$ (50 mW)
Operating range	2 to 10 VDC 2 to 10 V phasecut
Output signal	2 to 10 VDC (adjustable) max .5 mA
Direction of rotation	reversible with switch A/B
Positioning range	adjustable max. = 0.2 to 1 (approx. 20 to 90° rotation angle) min. 0 to 80% of max.
Measuring voltage U	2 to 10 VDC (max 0.5 mA) for position 0 to 1
Ambient temperature	-4°F to +122°F [-20°C . . . +50°C]
Storage temperature	-40°F to +176°F [-40°C to +80°C]
Housing	NEMA type 2
Housing rating	UL94V-0 (flammability rating)
Quality standard	ISO 9001
Weight	14 oz [400 g]

## Dimensions







## Air Damper Actuator Documentation

### Overview

Doc. 1.0 Product Guide and  
Company Profile (list prices)

### Spring Return Actuators

Doc. 2.1 AF Series, 133 in-lb  
Doc. 2.2 NF Series, 60 in-lb  
Doc. 2.3 LF Series, 35 in-lb

### Non-Spring Return Actuators

Doc. 3.1 GM Series, 266 in-lb  
Doc. 3.2 AM Series, 166 in-lb  
Doc. 3.3 NM Series, 70 in-lb  
Doc. 3.4 LM Series, 35 in-lb

### Accessories

Doc. 4.1 Electronic Accessories  
Doc. 4.2 Mechanical Accessories

### Application Information

Doc. 5.1 Mounting Methods Guide  
Doc. 5.2 Wiring Guide  
Doc. 5.3 Damper Applications Guide  
Doc. 5.4 Pneumatic vs Electronic Actuation  
Doc. 5.5... Actuator submittal sheets

### Product/Application News



## Control Valve Documentation

### Documentation/Price List

Doc. V2.1 Characterized Control Valves  
Doc. V2.2 Electronic Globe Valves (1/2"-2")  
Doc. V2.2-1 Electronic Globe Valves (2 1/2"-6")  
Doc. V2.3 Electronic Zone Valves  
Doc. V2.4 Electronic Butterfly Valves

### Application Information

Doc. V4.1 Sizing and Selection  
Doc. V4.2 Valve Applications Guide

### Product/Application News

## Belimo InterActive®

Complete product catalog and selection software  
for damper actuators and control valves –

On **CD-ROM** or the internet at [www.belimo.com](http://www.belimo.com)



## Serving HVAC Professionals Throughout the Americas

**Belimo Aircontrols (USA), Inc.**  
Corporate Headquarters/Manufacturing  
Distribution/Customer Service Center  
Latin American Customer Service  
43 Old Ridgebury Road, P.O. Box 2928  
Danbury, CT 06813  
(800) 543-9038 • (203) 791-9915  
Fax (203) 791-9919  
**Toll free fax order line:**  
**1-800-ACTUATE (1-800-228-8283)**

**Belimo Aircontrols (USA), Inc.**  
Distribution/Customer Service Center  
4900 Mill Street, Unit #9  
Reno, NV 89502  
(800) 987-9042  
(775) 857-4243  
Fax (775) 857-4255  
**Toll free fax order line:**  
**1-800-987-8875**

**Belimo Aircontrols (CAN), Inc.**  
Corporate Headquarters  
Distribution/Customer Service Center  
14/15 - 5716 Coopers Avenue  
Mississauga, Ontario L4Z 2E8  
(905) 712-3118  
Fax (905) 712-3124

**Belimo Servomoteur, Inc.**  
Corporate Headquarters  
Customer Service Center  
2790 Chemin Du Lac  
Longueuil, Québec J4N 1B8  
(450) 928-1440  
Fax (450) 928-0050